



# HMI's inside-Out

Tipps und Tricks from Design to Production

Sebastian Gepp | Head of Printed Electronics | Kundisch GmbH & Co KG



# Agenda

- Phoenix Mecano and the Devision Enclosure
- Materials of HMI systems
- Membrane Keyboards and the making of it
- The path to hybrid electronics
- Touch Sensor Integration
- Assembly of HMI Systems

## Phoenix Mecano AG, Switzerland



# Enclosures

Rose

■ HMI Solutions



■ Industrial Systems



■ Ex Equipment



Kundisch

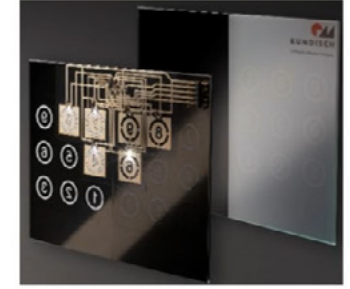

Bopla





# Enclosures

Rose

■ HMI Solutions



■ Industrial Systems

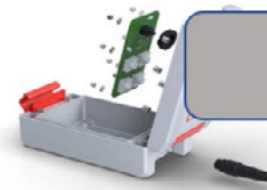

■ Ex Equipment



Metal Enclosures

Kundisch

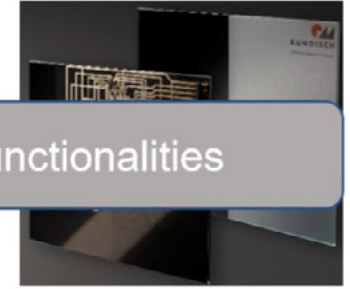
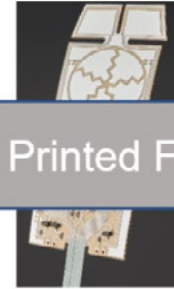
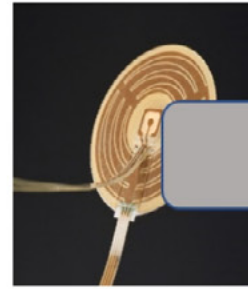

Printed Functionalities

Bopla

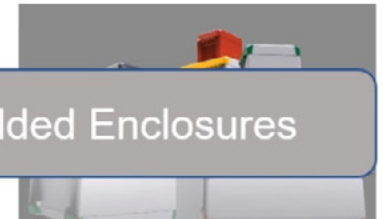

Plastic Molded Enclosures



# Kundisch Headquarter

- 40 Employees
- 12 Mio € Revenue
- Industries
  - Med Tech
  - Mechanical Engineering
  - Military
  - White Goods
  - Telecommunications
  - Automotive



# History

- 1979 Founding of Kundisch electronic
- 1982 Starting to produce membrane Keyboards on printed substrates
- 1991 Kundisch merges into Phoenix Mecano AG
- 1997 New Production Center Kecskemét, Hungary
- 2005 Start of the Competence Center Touch lamination in Schwenningen
- 2008 Expansion of the productions equipment for touch systems
- 2016 New production floor space in Hungary (Clean Room)
- 2018 Start to get active in printed electronics



# History of Membrane Keyboards





# History of Membrane Keyboards

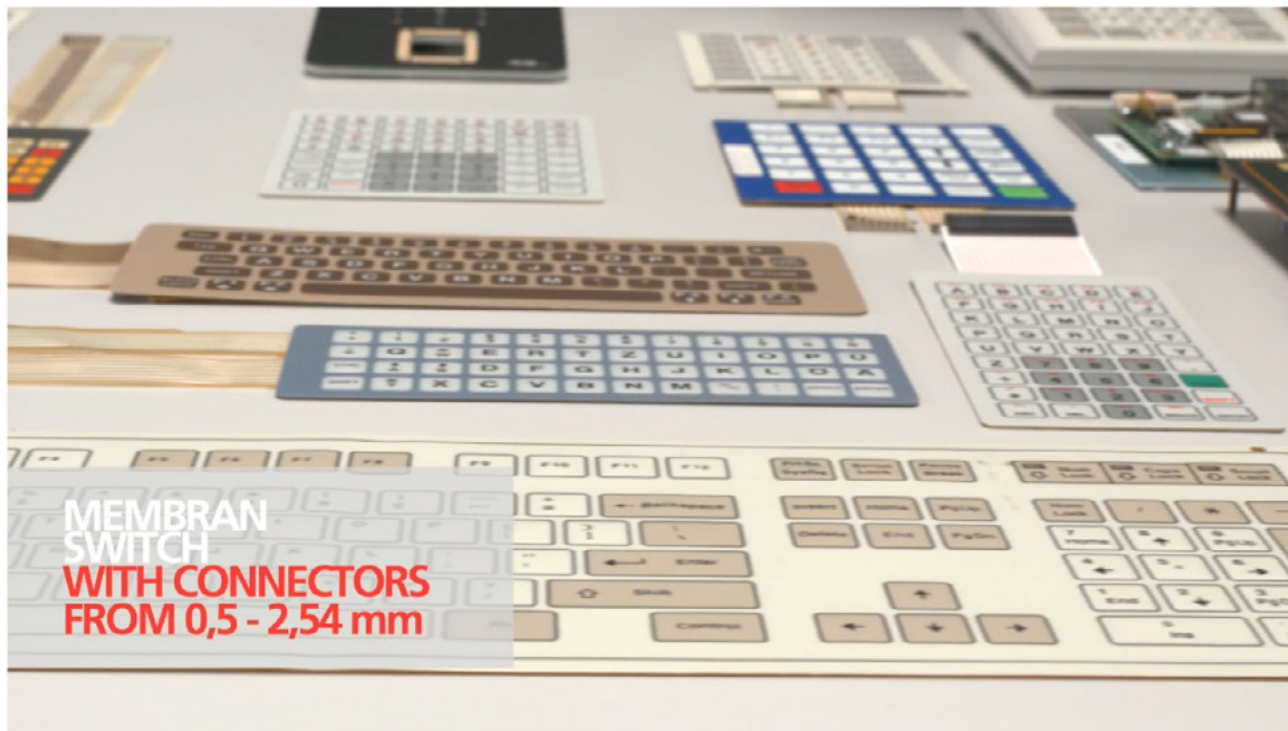

MEMBRAN  
SWITCH  
WITH CONNECTORS  
FROM 0,5 - 2,54 mm

# History of Membrane Keyboards

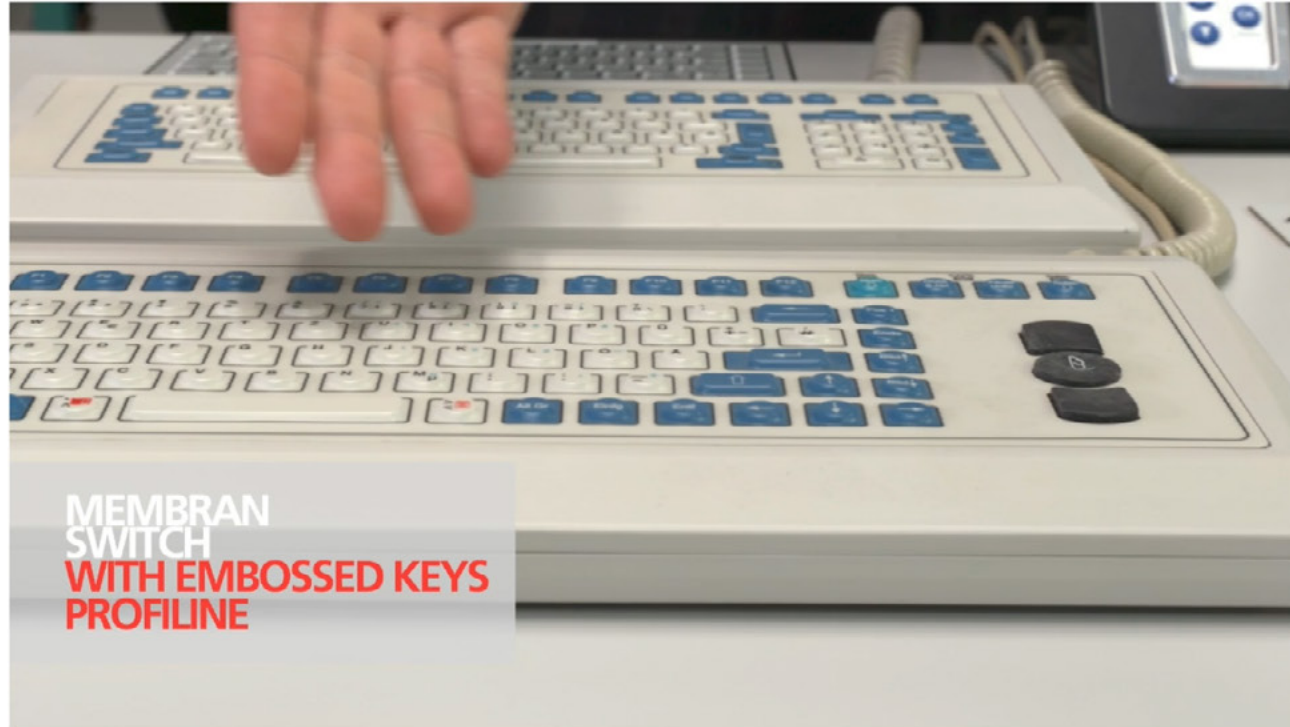



# History of Membrane Keyboards

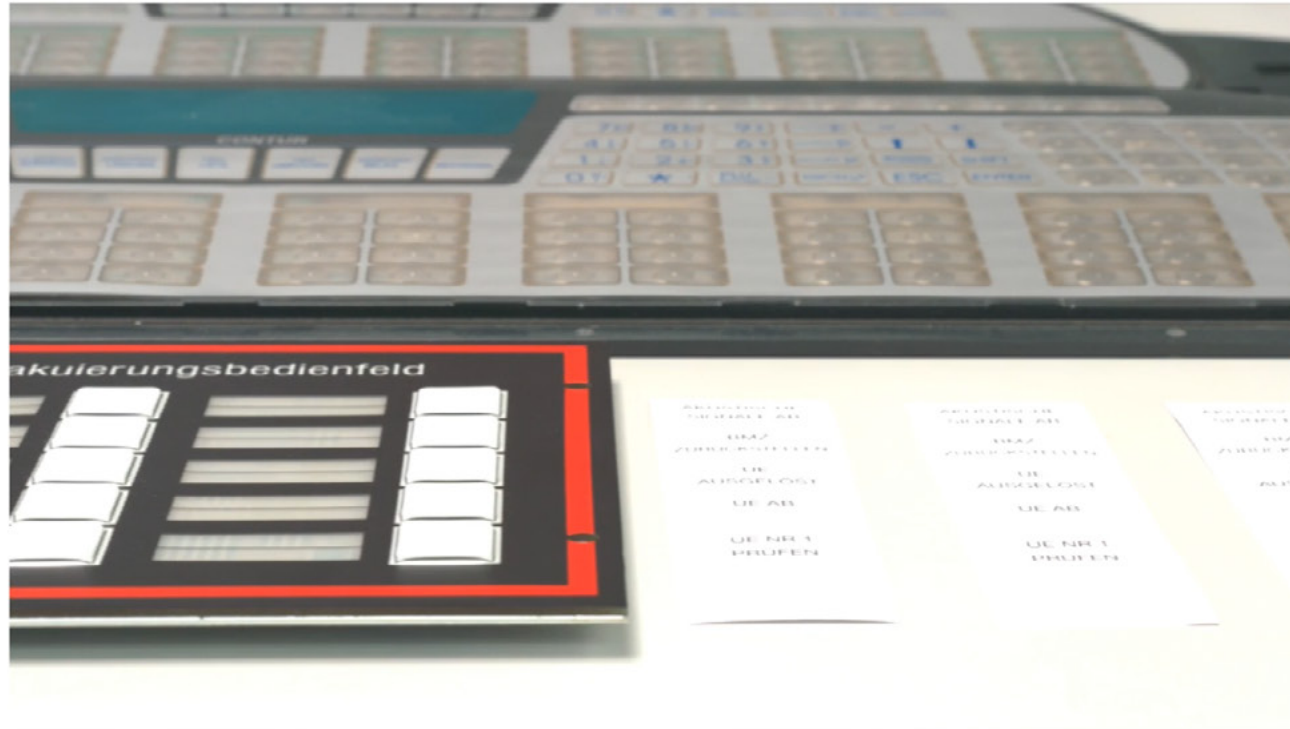

# History of Membrane Keyboards

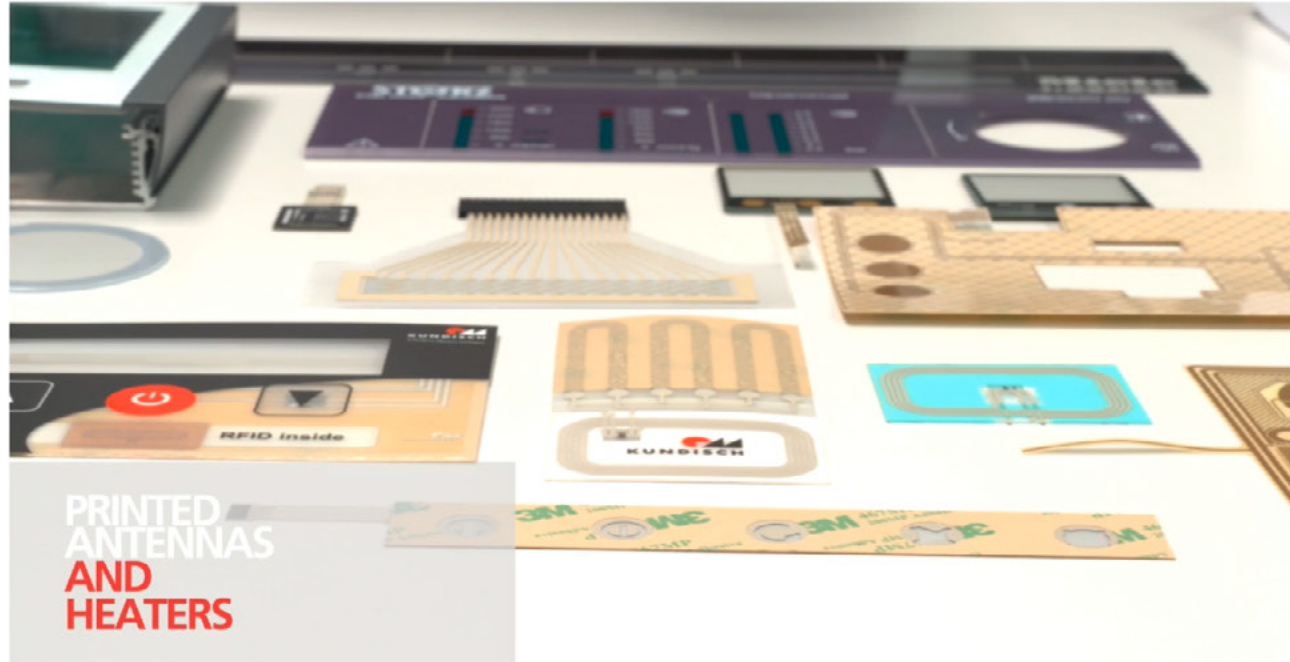

# History of Membrane Keyboards



# History of Membrane Keyboards



# History of Membrane Keyboards









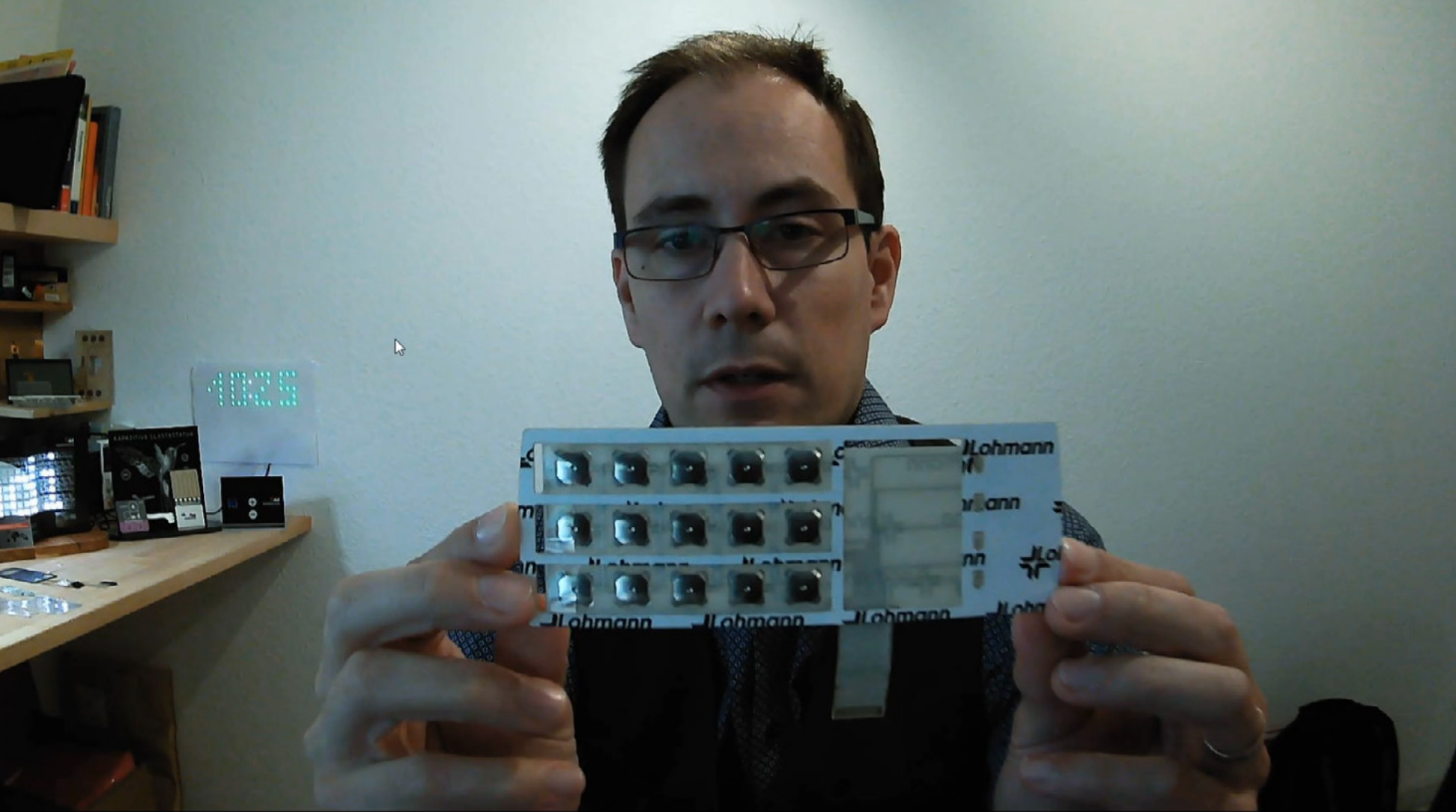

# Production Technology at Kundisch

- S2S Screen Printing up to 700x1200mm
  - 21.000m<sup>2</sup> of material is processed every year
  - mainly copper laminates are processed and enriched by printed silver and other materials
- Reflow Soldering on PET up to 430x310mm
- more than 5 Mio components are soldered on flexible circuitry every year.
- Lamination, Laser cutting, Embossing
- Clean Room class 6 fabrication for highest quality
- ISO 9001 certified
- 1 Mio printed products are delivered to customers all over the world



Printing machines in clean room



## Factory in Kecskemet Hungary

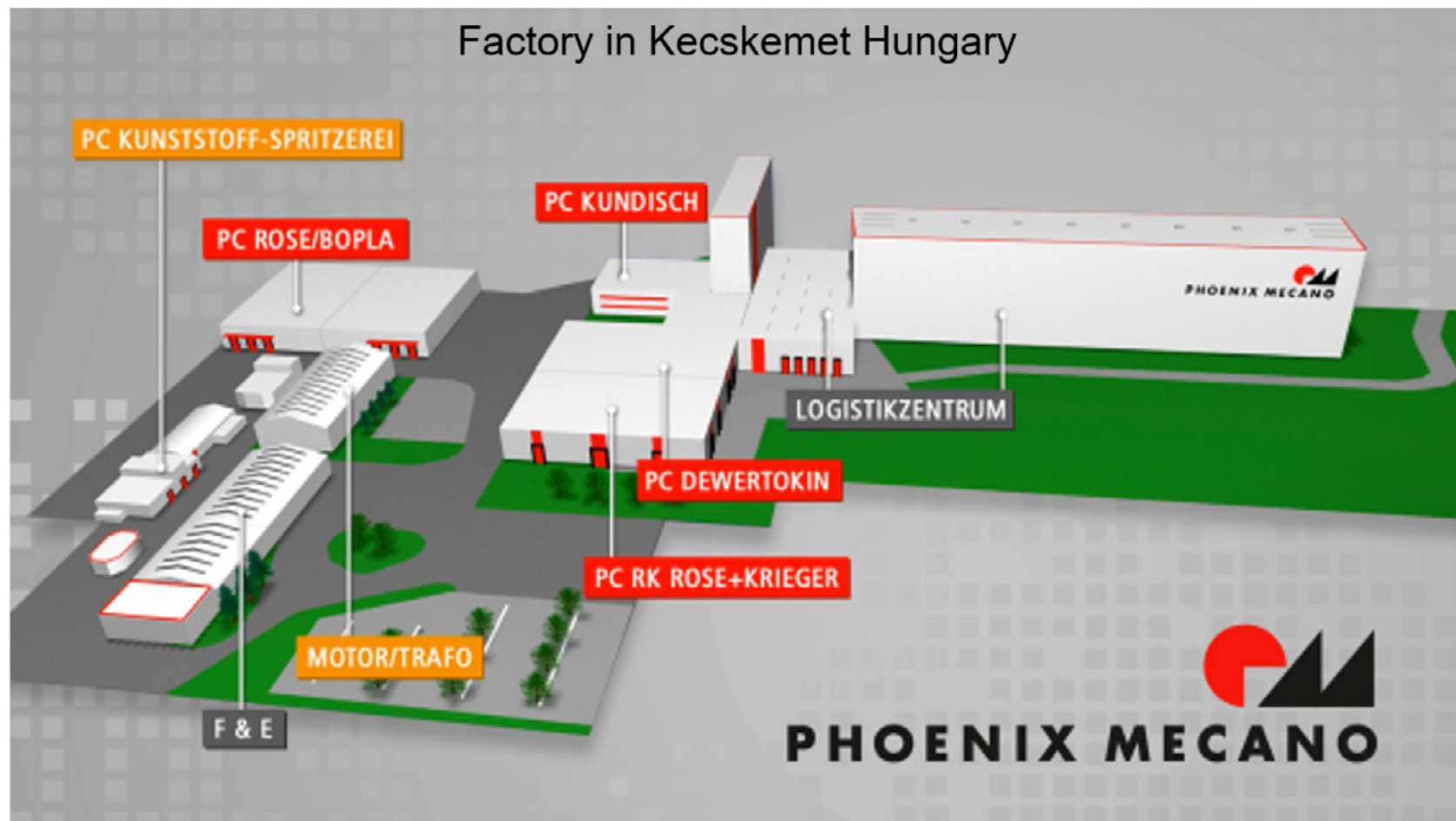



## Process Center

Rose / Bopla

Electric Enclosures  
from plastic or  
aluminium



## Process Center

Injection Moulding

Plastic Components



4



## Process Center

Rose + Krieger

Linear Positioning units

Aluminium Profiles

Engine Systems

Protection Systems





# Process Center

Rose + Krieger

Linear Positioning units

Aluminium Profiles

Engine Systems

Protection Systems



# R+D Kecskemet Hungary

Product and Process Development

New Production technologies

Injection Molding Tool Design and Milling

Lab Testing and Measurements

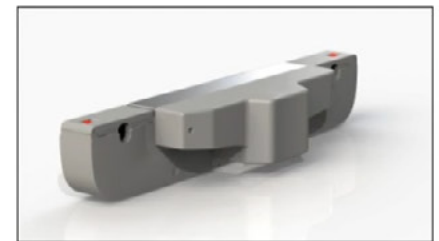
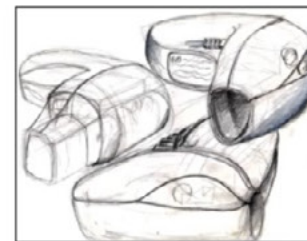
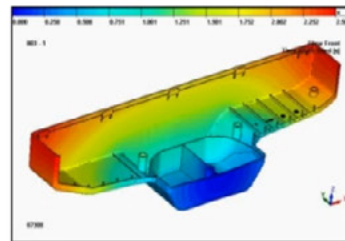
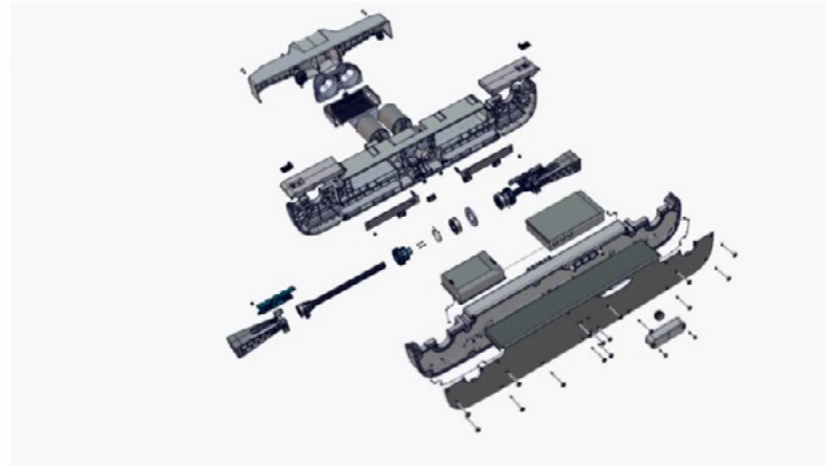

# Insides of HMIs

# Materials of HMI Systems



Glas



Plastic Films



Paper

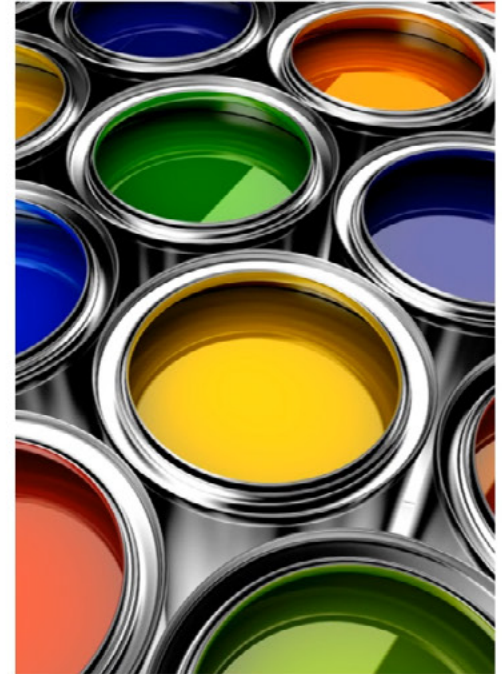

Inks



# Materials of HMI Systems



Adhesives

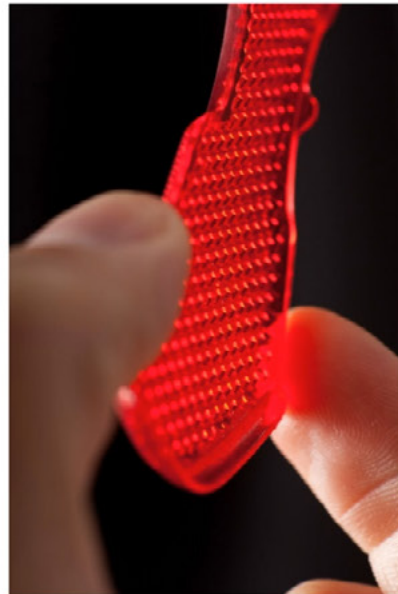

Light Guides



Metal Domes



Electrical Components

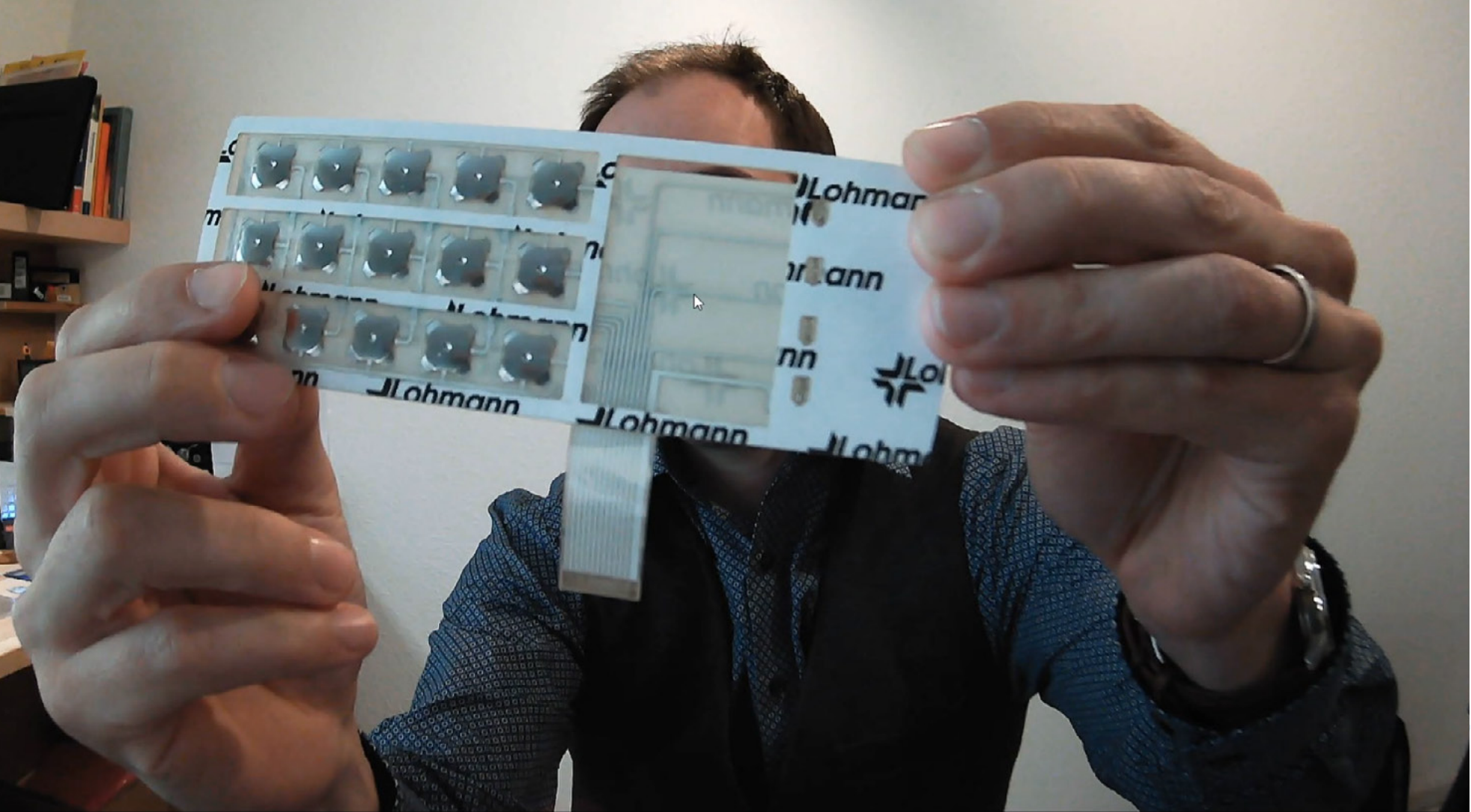



# Conductors

Printed Silver

Printed Copper

Etched Copper

Printed Carbon

Printed Sensor Inks

Printed transparent conductors

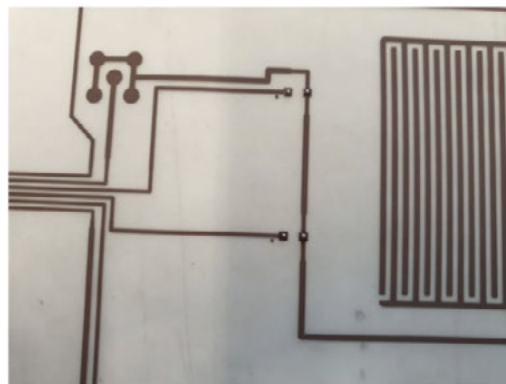

Printed Copper on PET



Printed Silver on PET



Printed Carbon on Paper



Etched Copper on PET

# Transparent Conductors

Pedot:PSS (additive)

Metal Mesh (subtractive + additive)

CNT (additive)

Silver Nano Wire (subtractive + additive)

ITO (subtractive)

Depending on the application the best technology is selected

Transparency  $\approx$  80% in final setup including adhesives and enclosure

Most often used in combination with Illumination

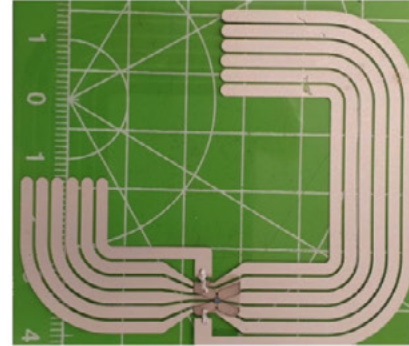

Partially transparent  
NFC Antenna

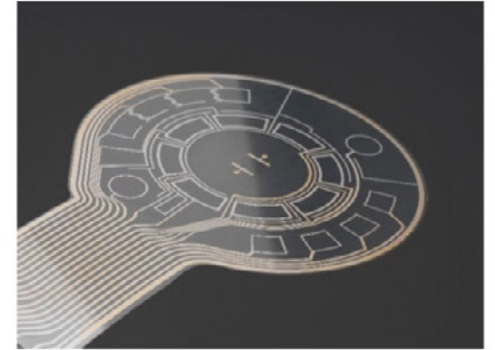

Pedot Touch sensor



Metal Mesh Sensor





# Basic Competencies

Printing  
Colors

Printing  
Conductors

Lamination  
of Films

Cutting of  
Films

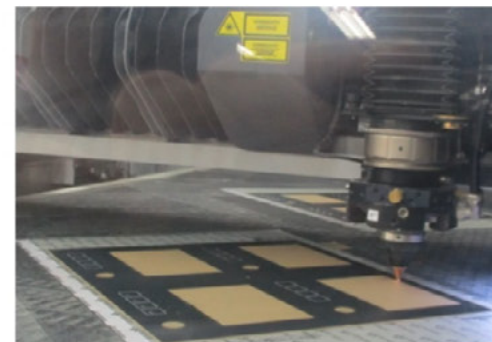
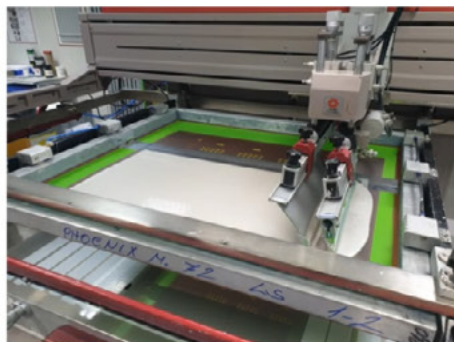



# Advanced Competencies

Electrical  
Design

Pick'n'  
Place

Soldering  
on PET

Embossing

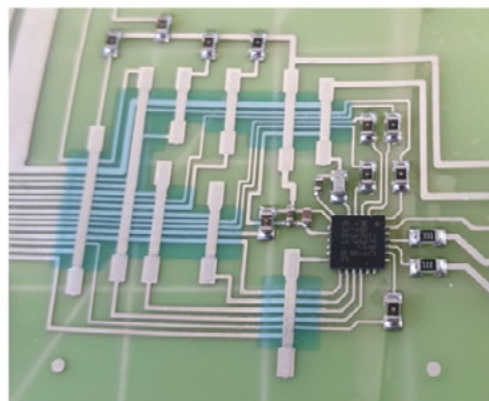
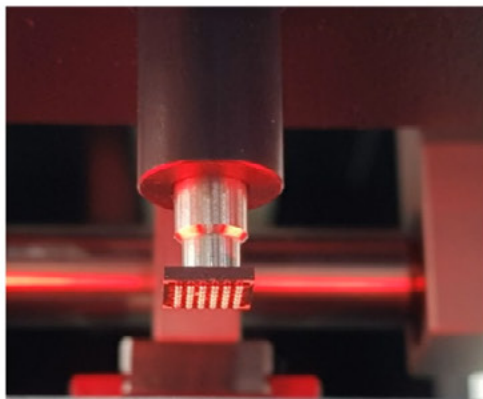
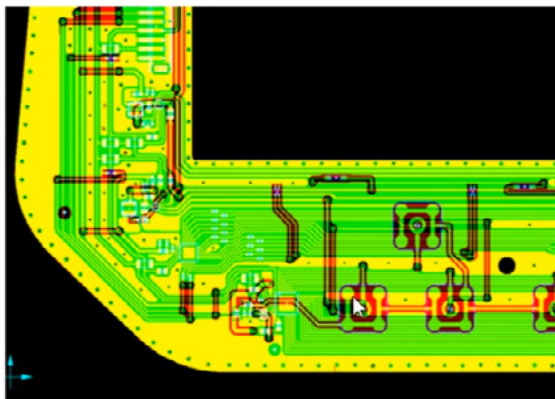

# Membrane Keyboards

- State of the Art Technology
- Relevant for many applications
  - Machinery
  - White Goods
  - Automotive
  - Medical Industry
- Robust and easily customizable
- Small volumes possible

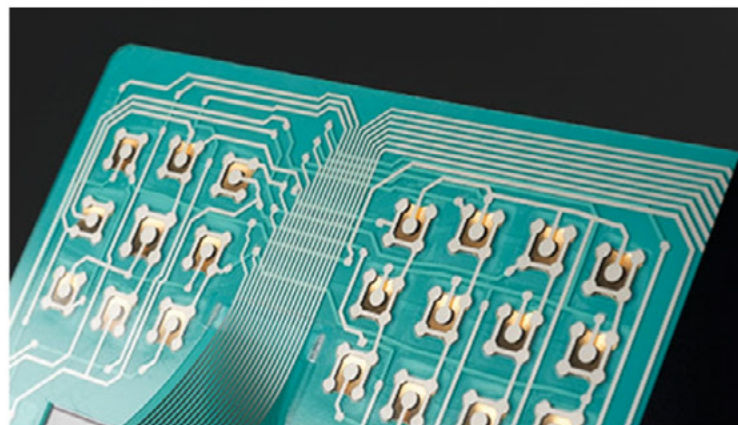

# Video of making a membrane keyboard

Siebdruck des  
Ätzresistes  
auf den  
Kupferbogen

# Video of making a membrane keyboard





# Video of making a membrane keyboard

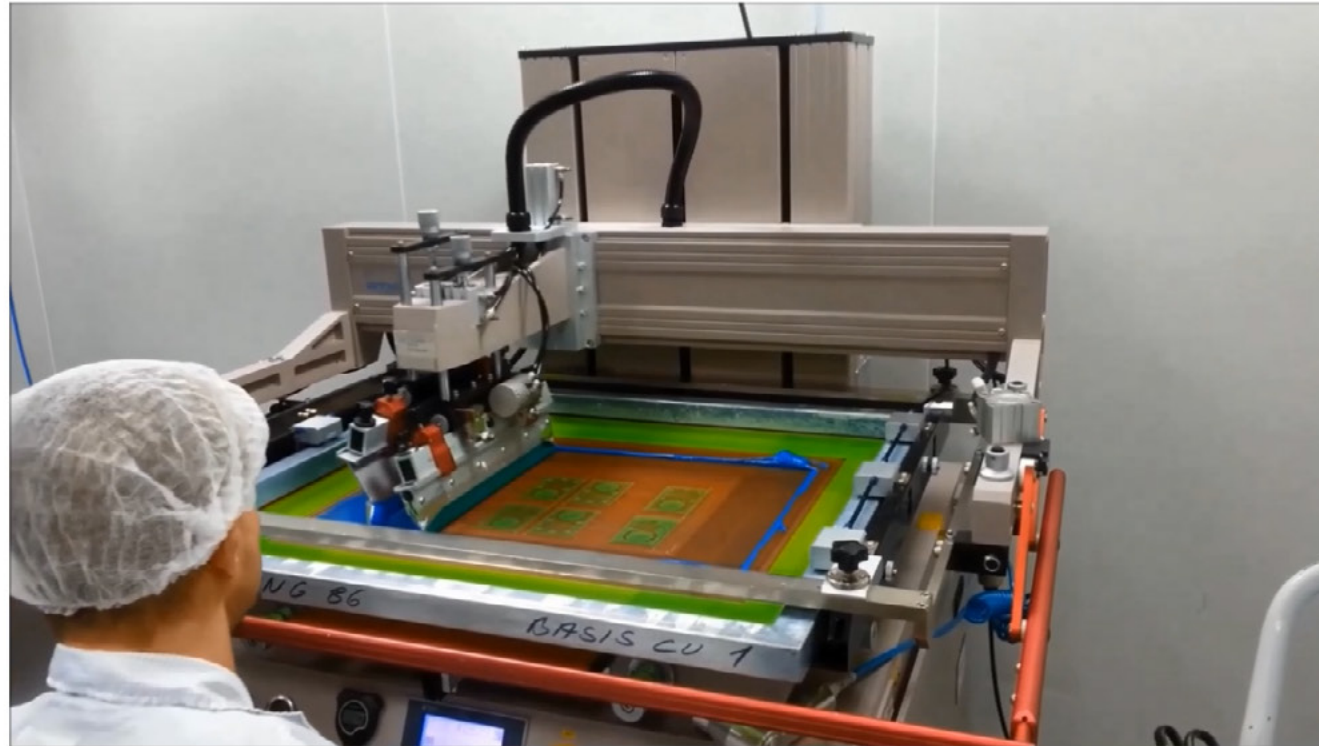

# Video of making a membrane keyboard



# Video of making a membrane keyboard

Ätzen des  
Schaltpaketes  
auf Kupferbasis

# Video of making a membrane keyboard

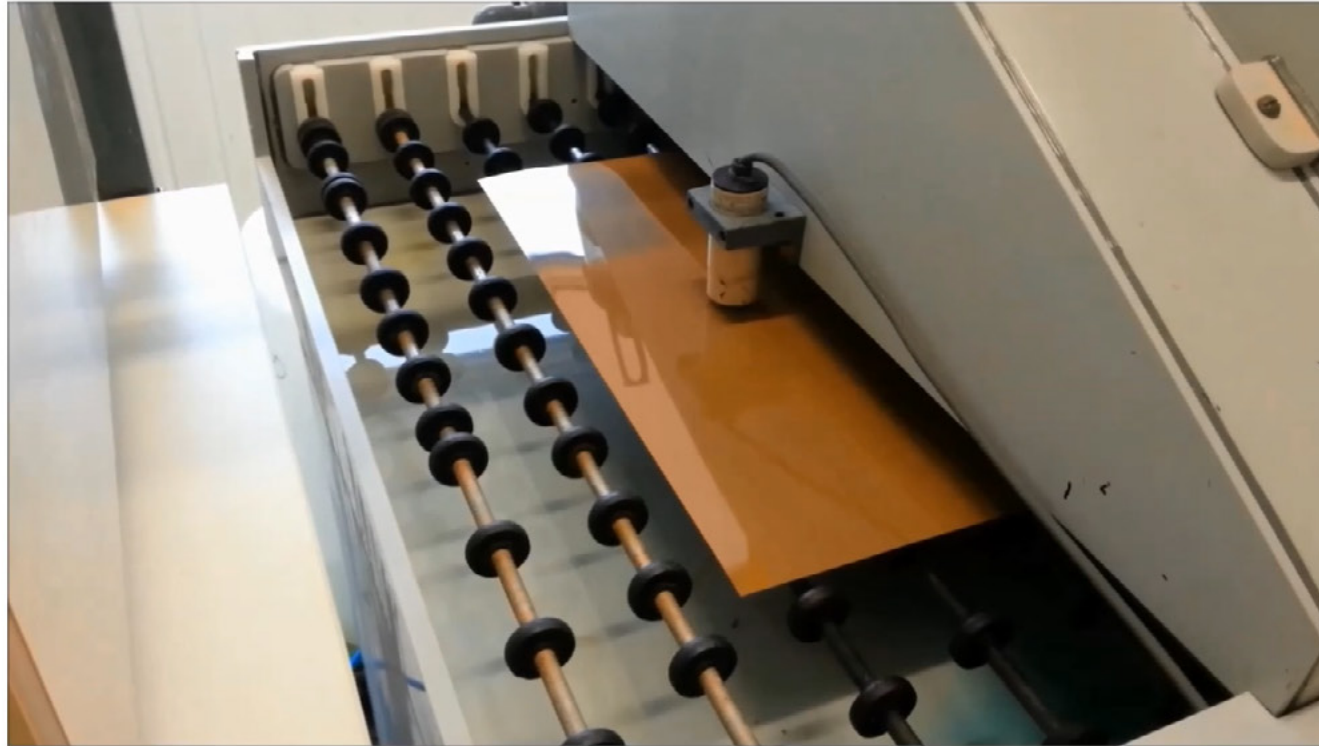



# Video of making a membrane keyboard



# Video of making a membrane keyboard

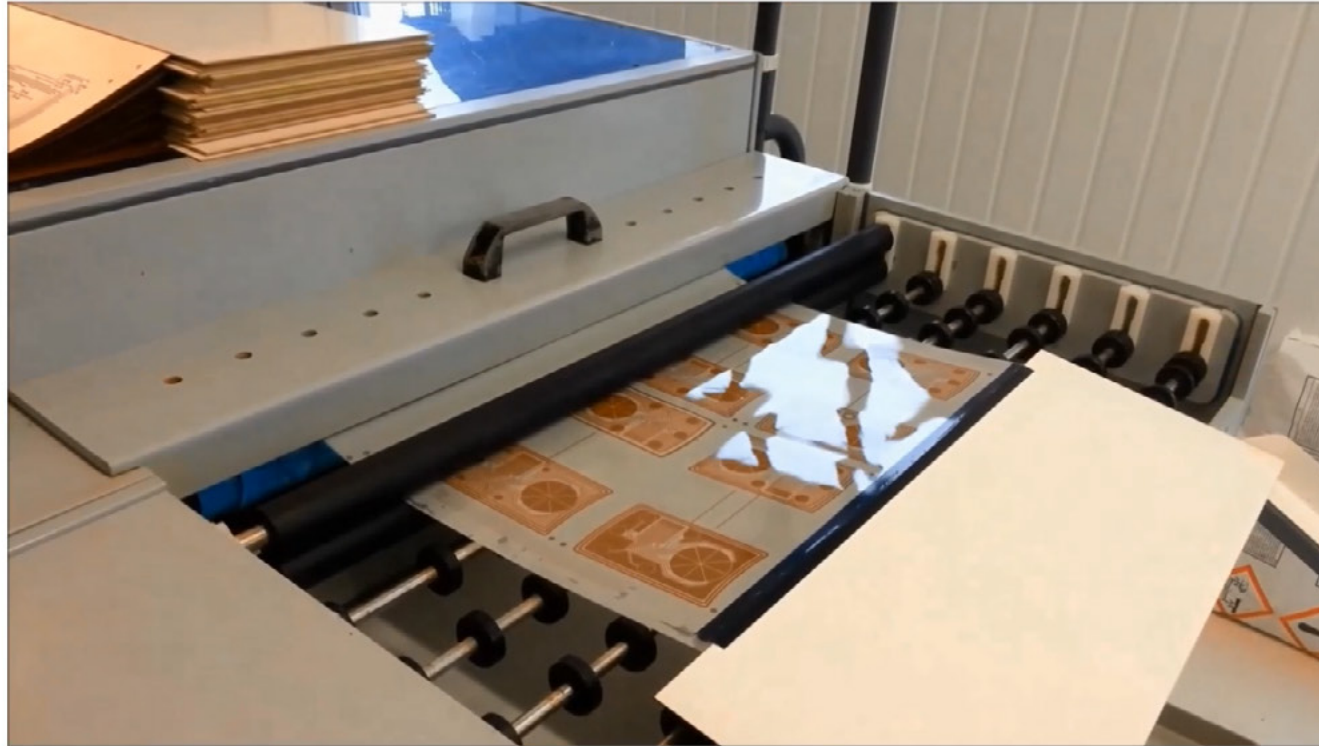

# Video of making a membrane keyboard

Versilbern des  
geätzten  
Kupferbogens

# Video of making a membrane keyboard





# Video of making a membrane keyboard

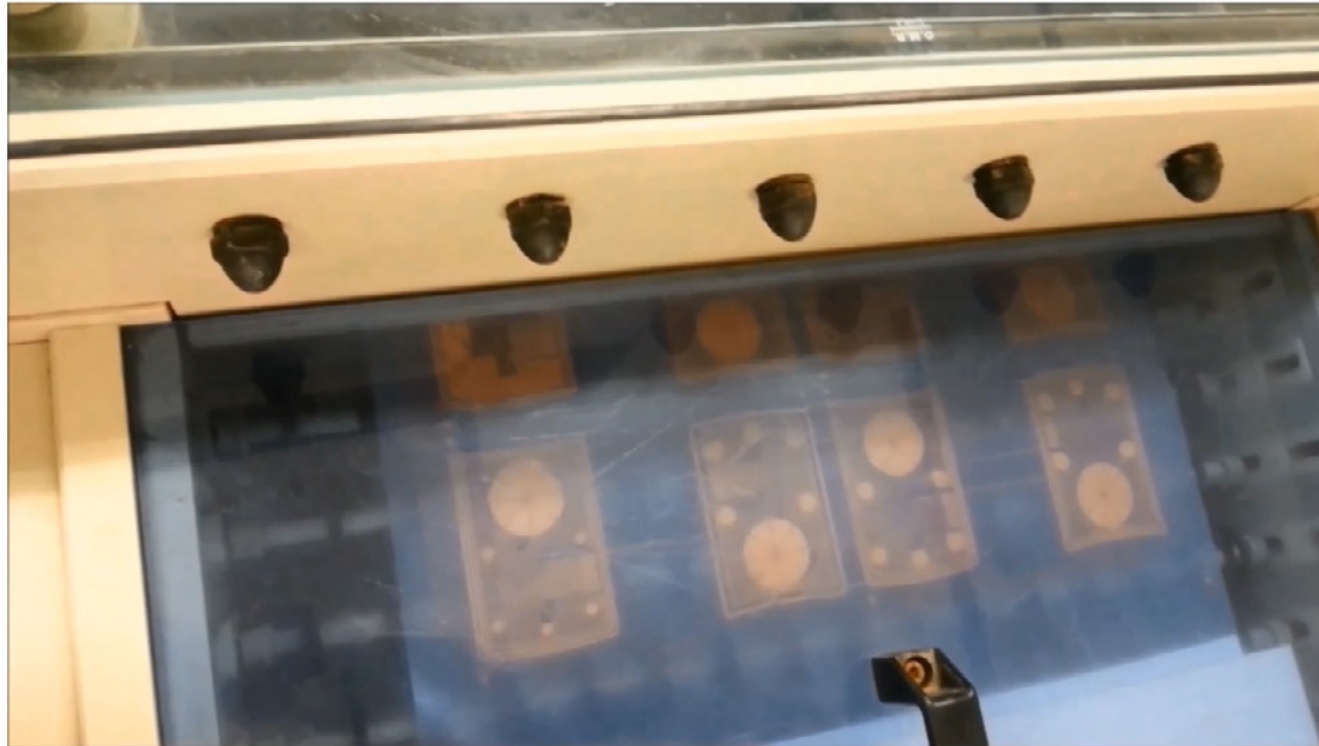

# Video of making a membrane keyboard

Siebdruck der  
Frontfolie

# Video of making a membrane keyboard

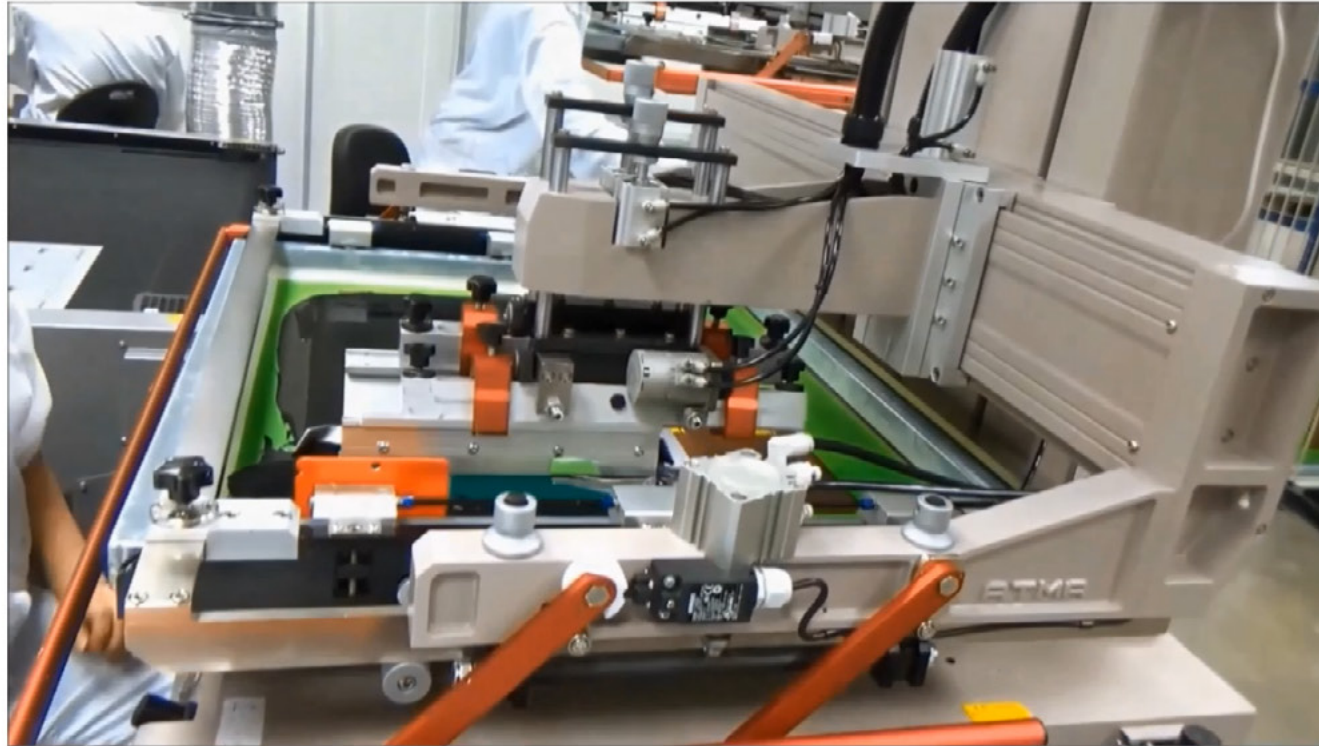

# Video of making a membrane keyboard

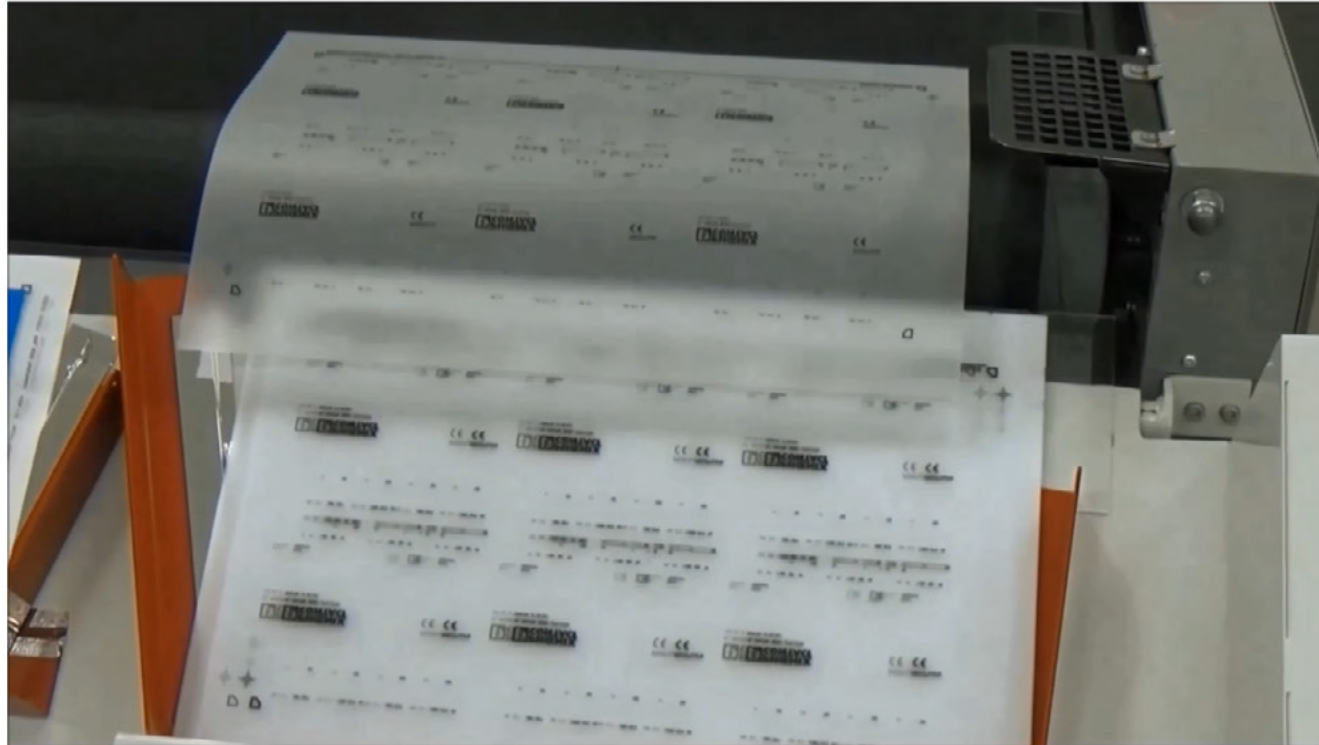



# Video of making a membrane keyboard

Arbeitsvorbereitung,  
Plotten und Lasern

# Video of making a membrane keyboard

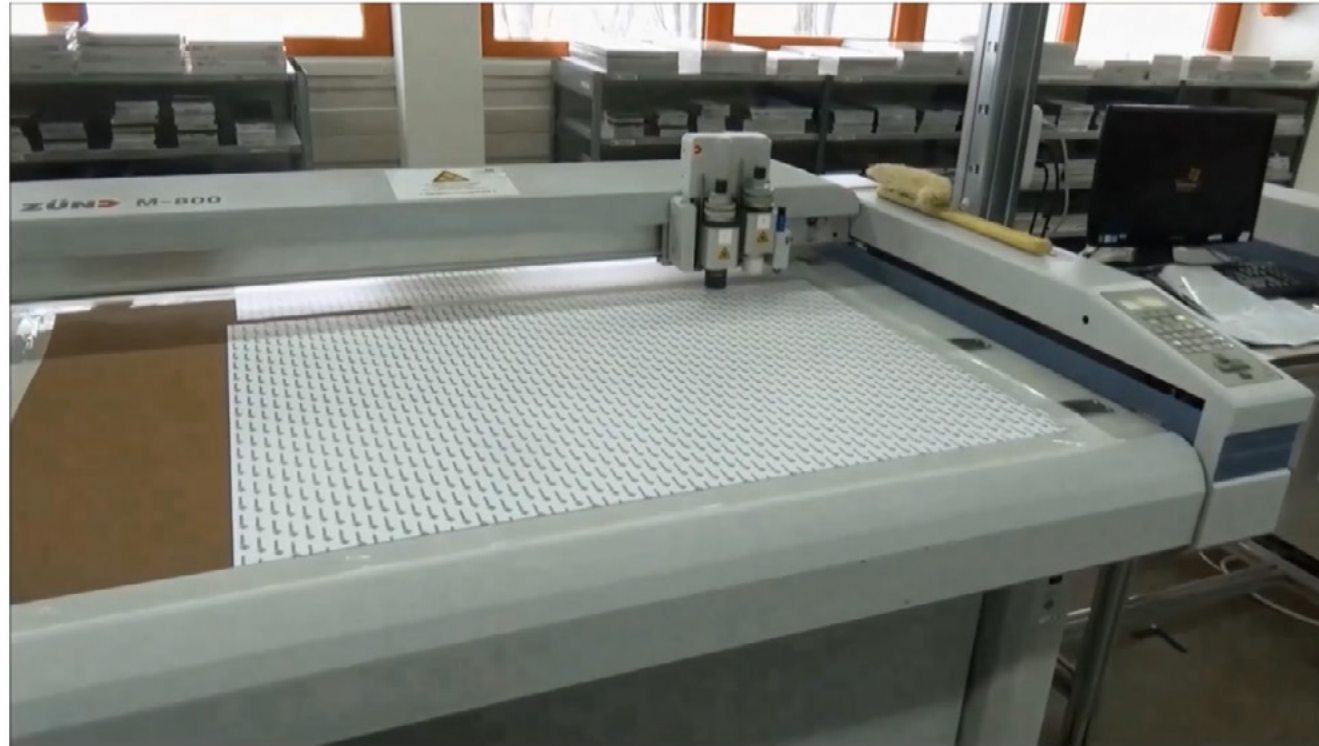

# Video of making a membrane keyboard



# Video of making a membrane keyboard

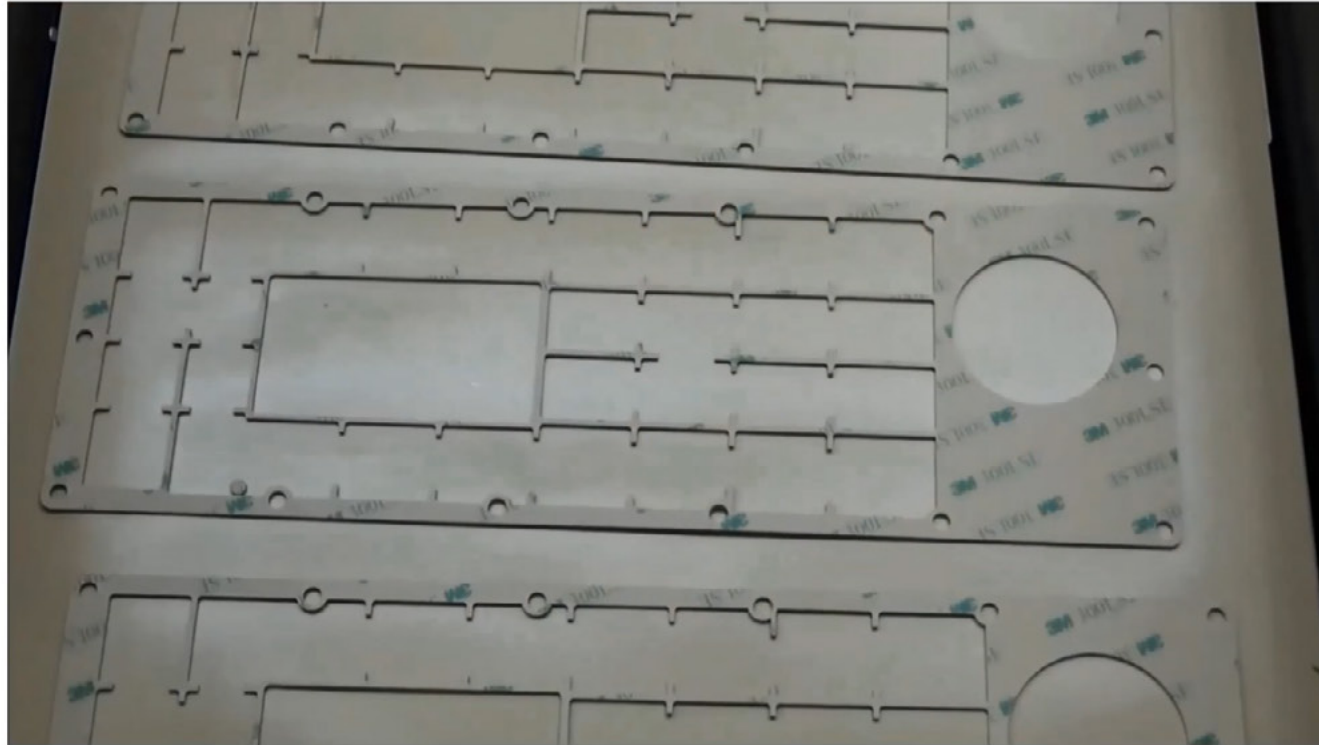



## Video of making a membrane keyboard

Tastenprägung

# Video of making a membrane keyboard



## Video of making a membrane keyboard

Aufbringen  
Klebeschicht

# Video of making a membrane keyboard

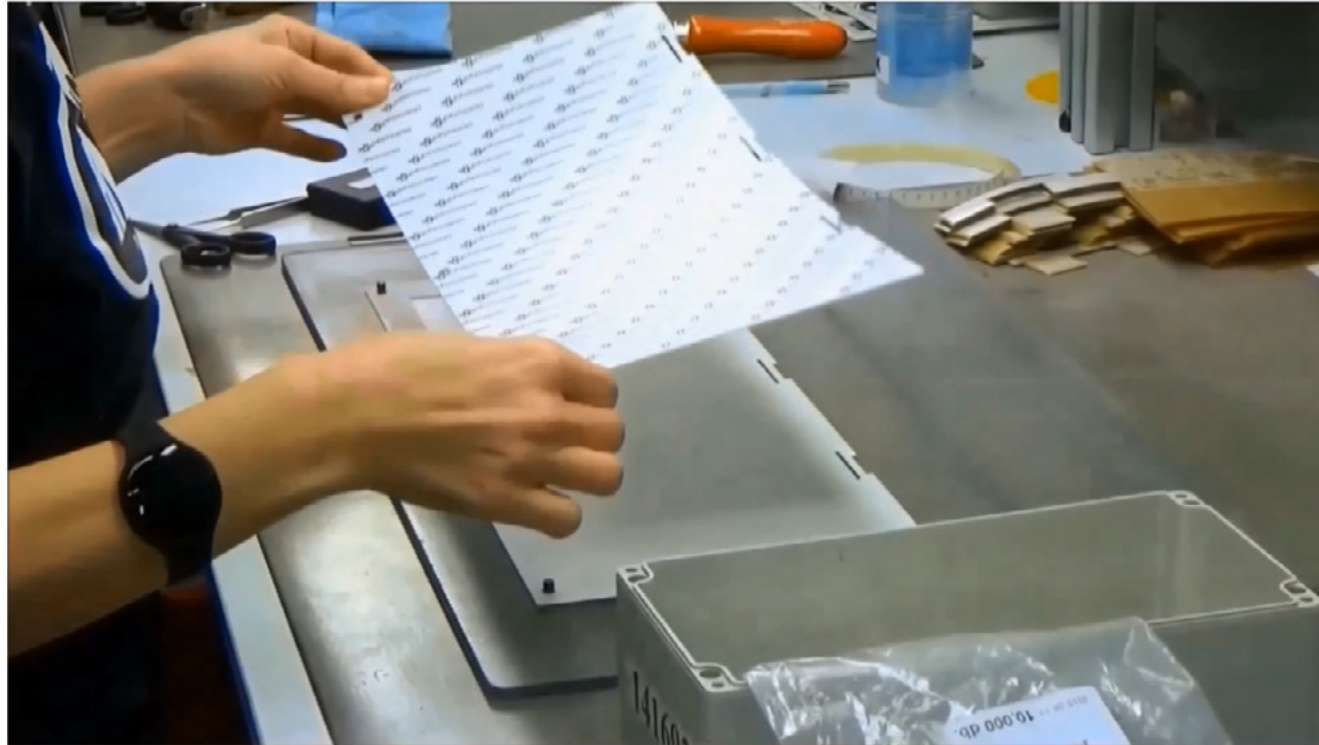



# Video of making a membrane keyboard



# Video of making a membrane keyboard

Einkleben des  
Schaltpaketes

# Video of making a membrane keyboard



# Video of making a membrane keyboard

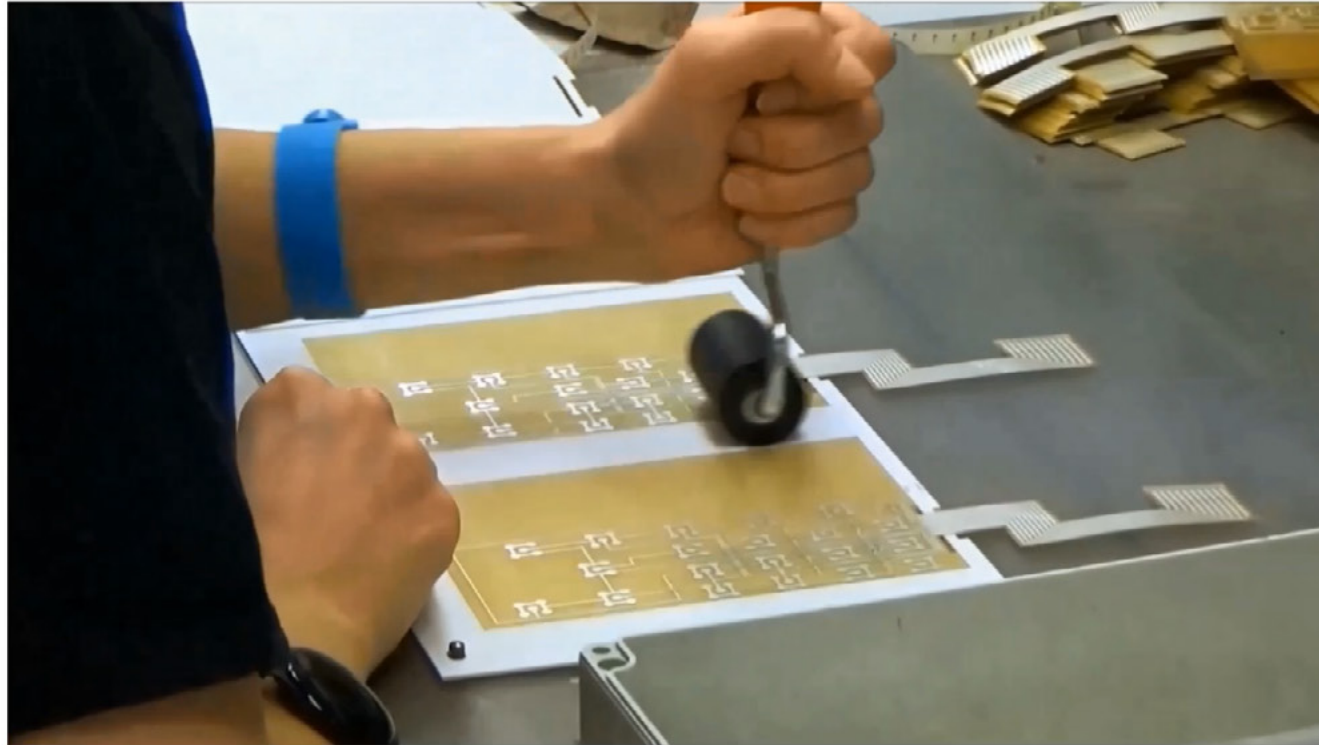



# Video of making a membrane keyboard

Aufbringen einer  
weiteren  
Klebeschicht

# Video of making a membrane keyboard

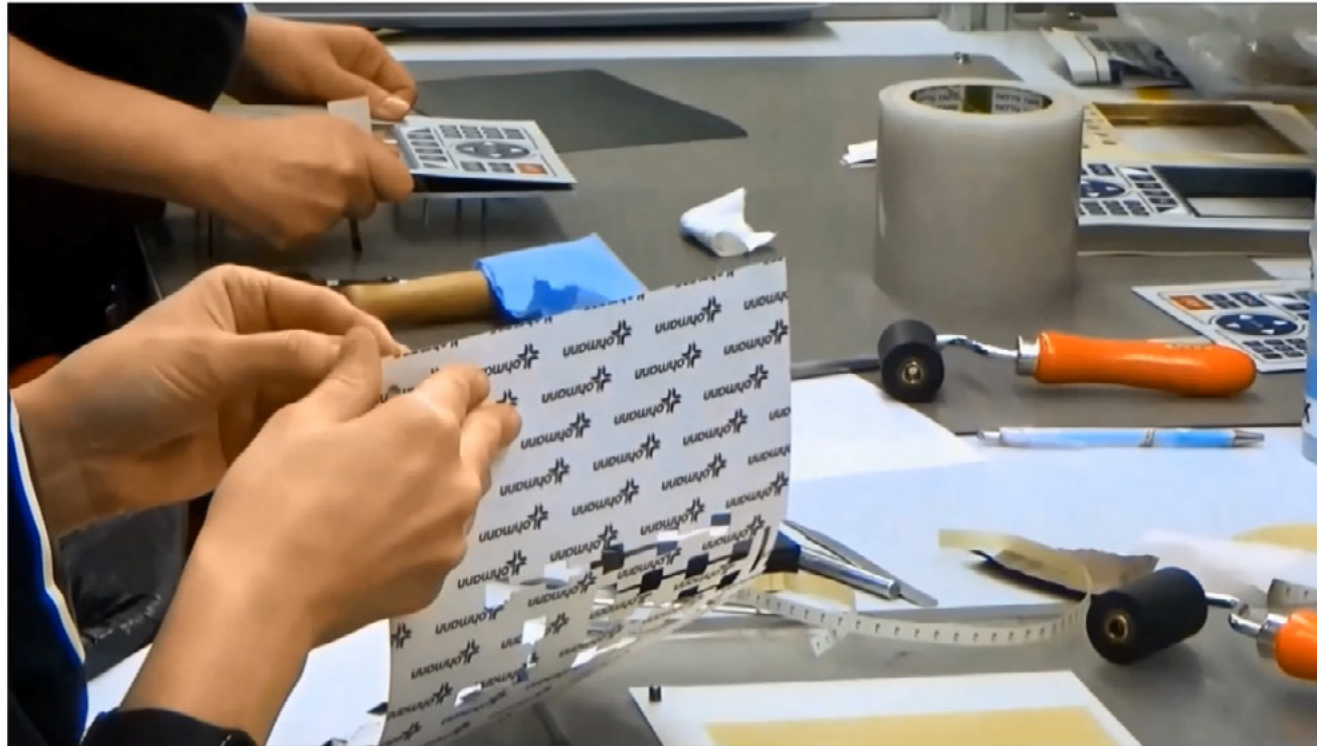

# Video of making a membrane keyboard

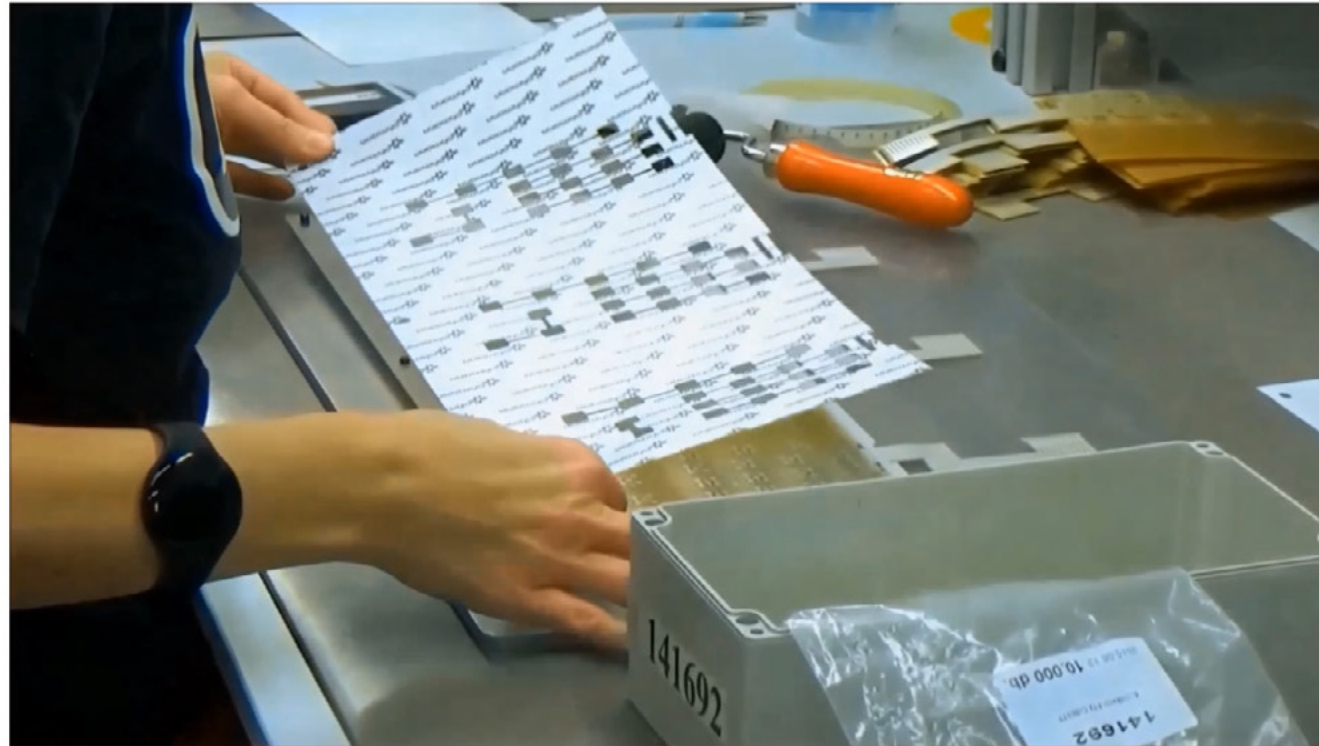

# Video of making a membrane keyboard





# Video of making a membrane keyboard

Setzen der  
Kontaktfedern



# Video of making a membrane keyboard

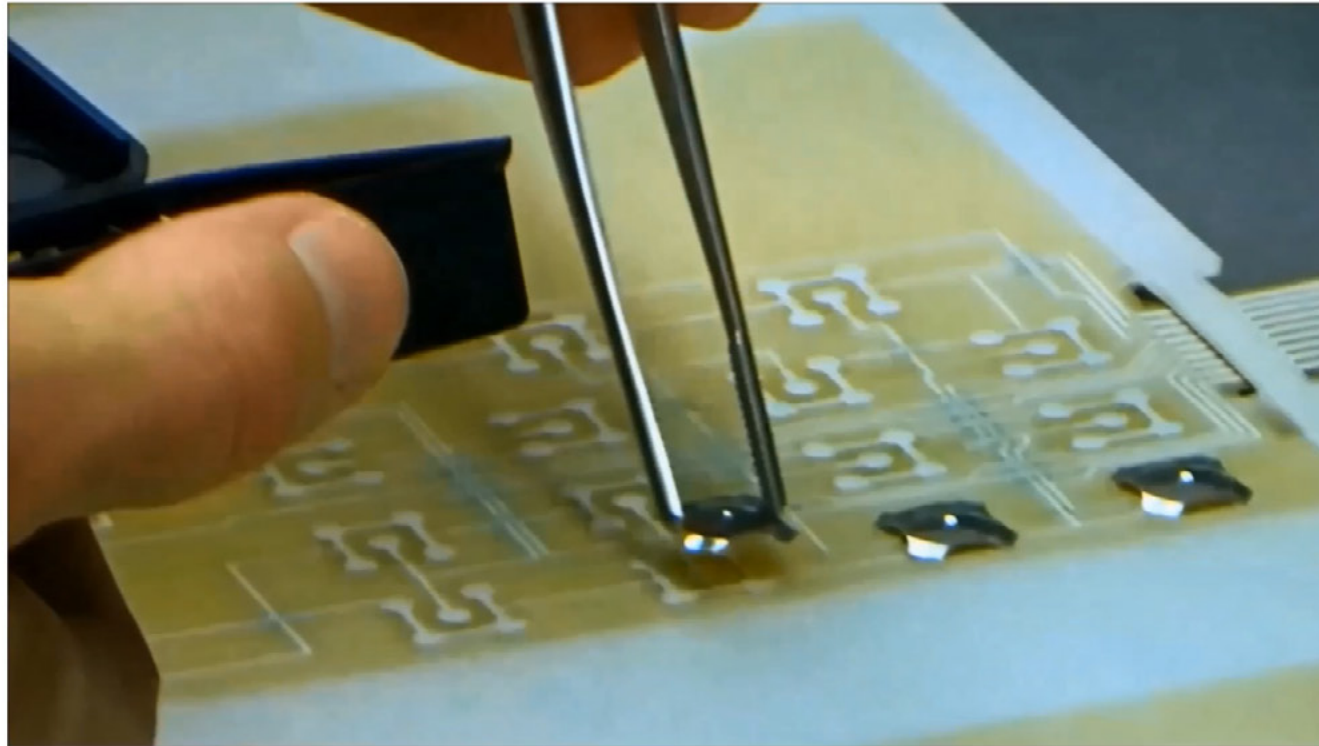

# Video of making a membrane keyboard

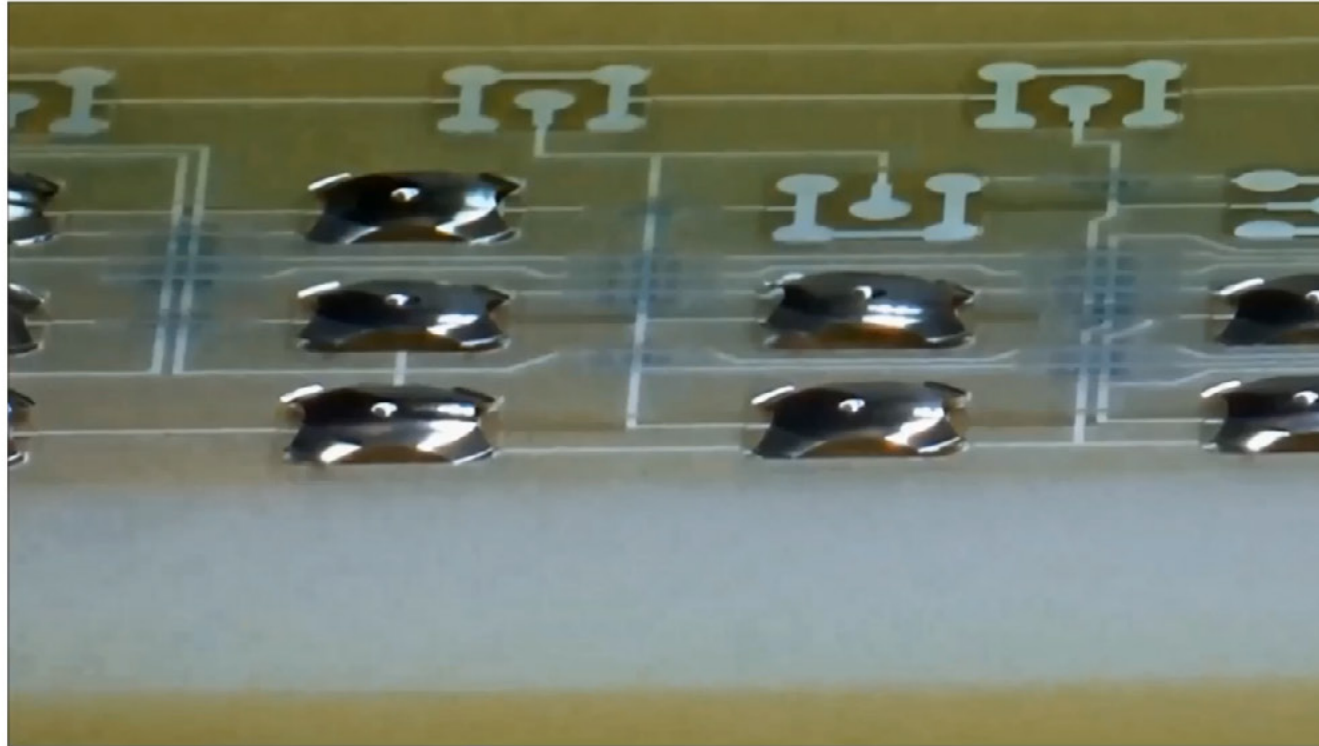

# Video of making a membrane keyboard

Aufbringen der  
SiKa



# Video of making a membrane keyboard

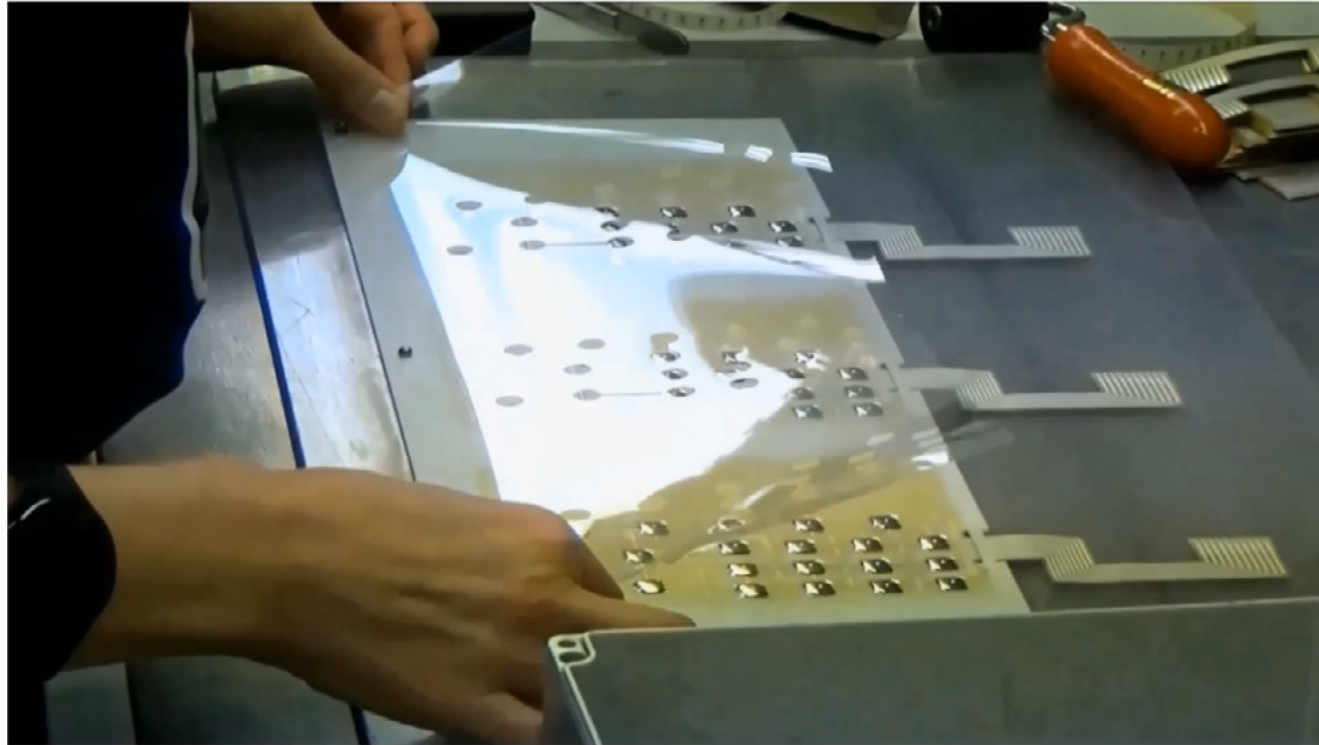

# Video of making a membrane keyboard

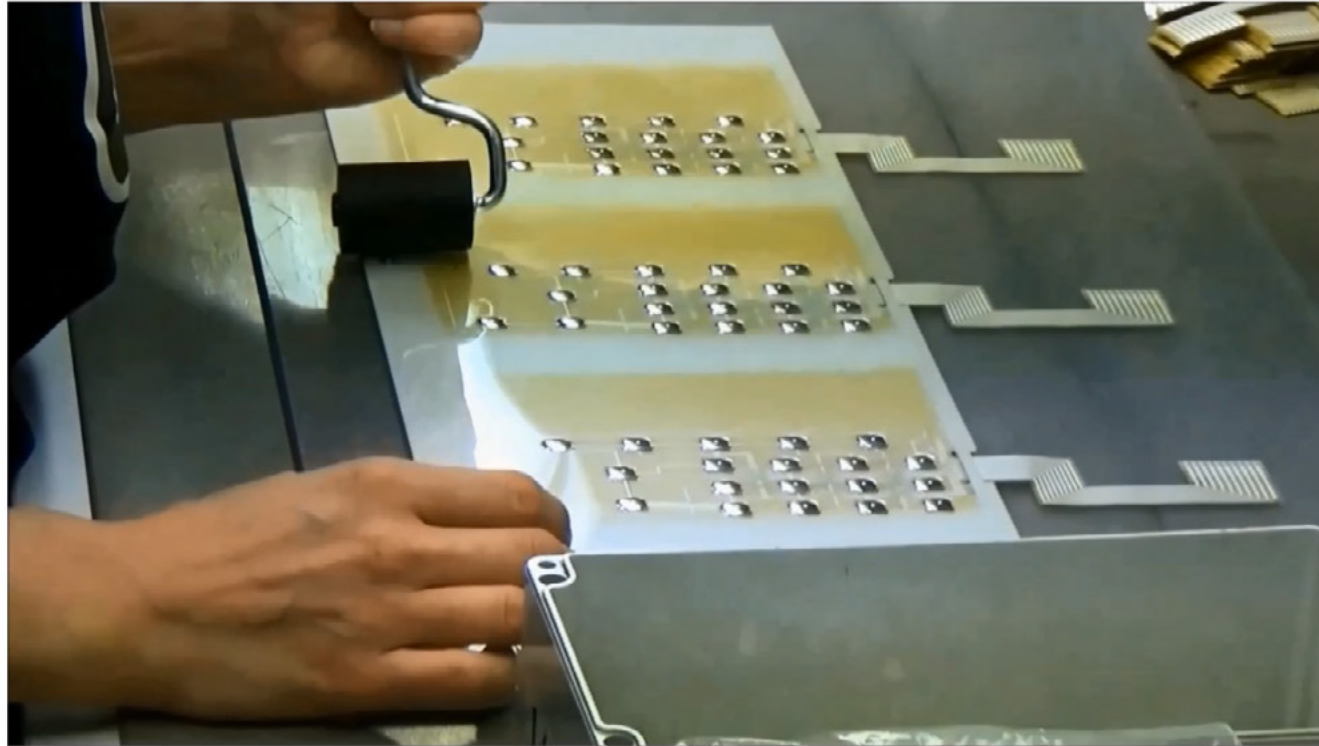

# Video of making a membrane keyboard

Aufbringen einer  
weiteren Klebeschicht

# Video of making a membrane keyboard





# Video of making a membrane keyboard



# Video of making a membrane keyboard

Frontfolie  
aufbringen

# Video of making a membrane keyboard



# Video of making a membrane keyboard

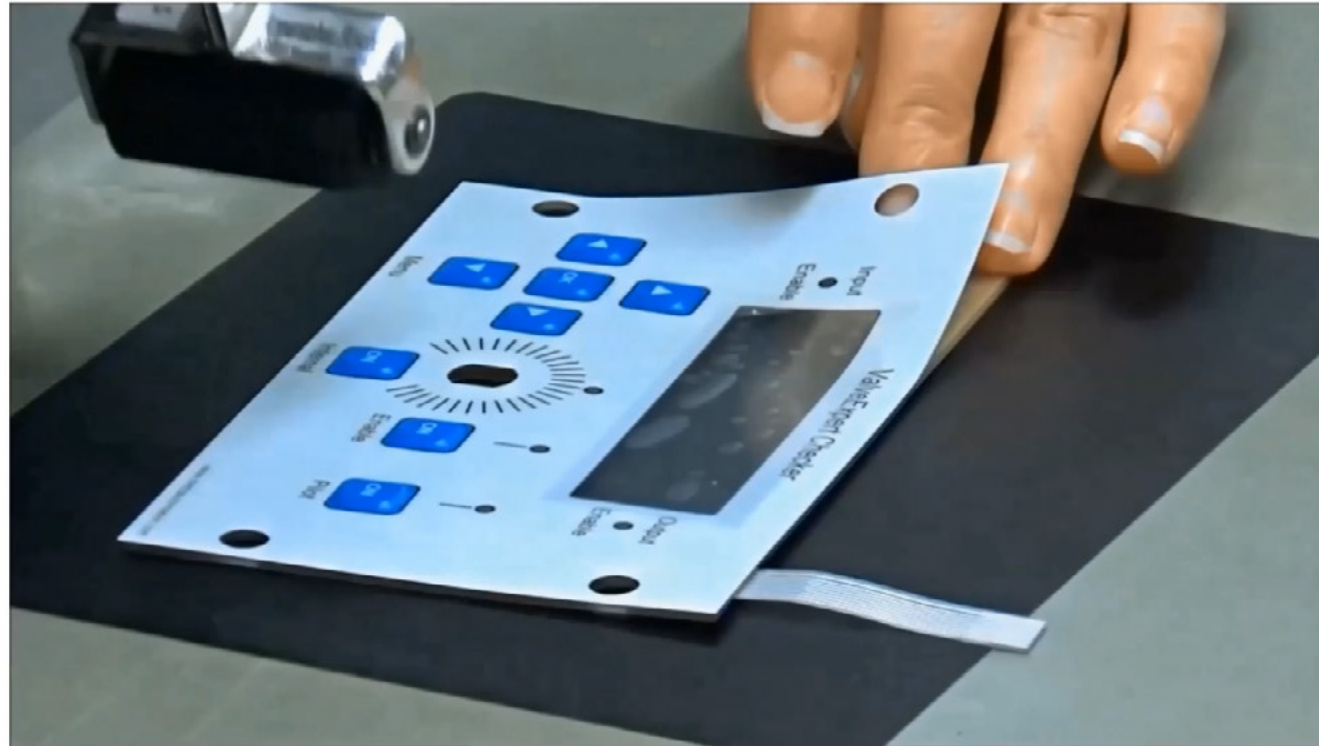



# Video of making a membrane keyboard



Endprüfung

# Video of making a membrane keyboard



# Video of making a membrane keyboard

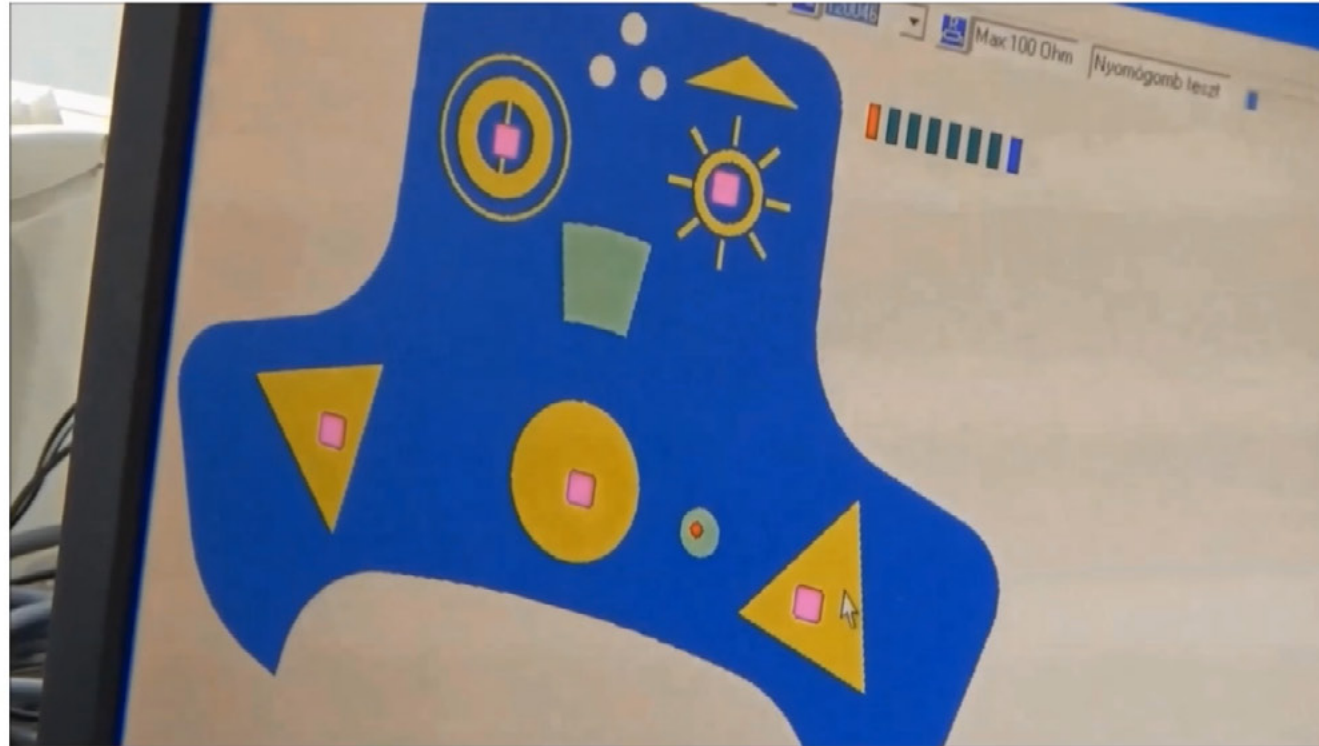

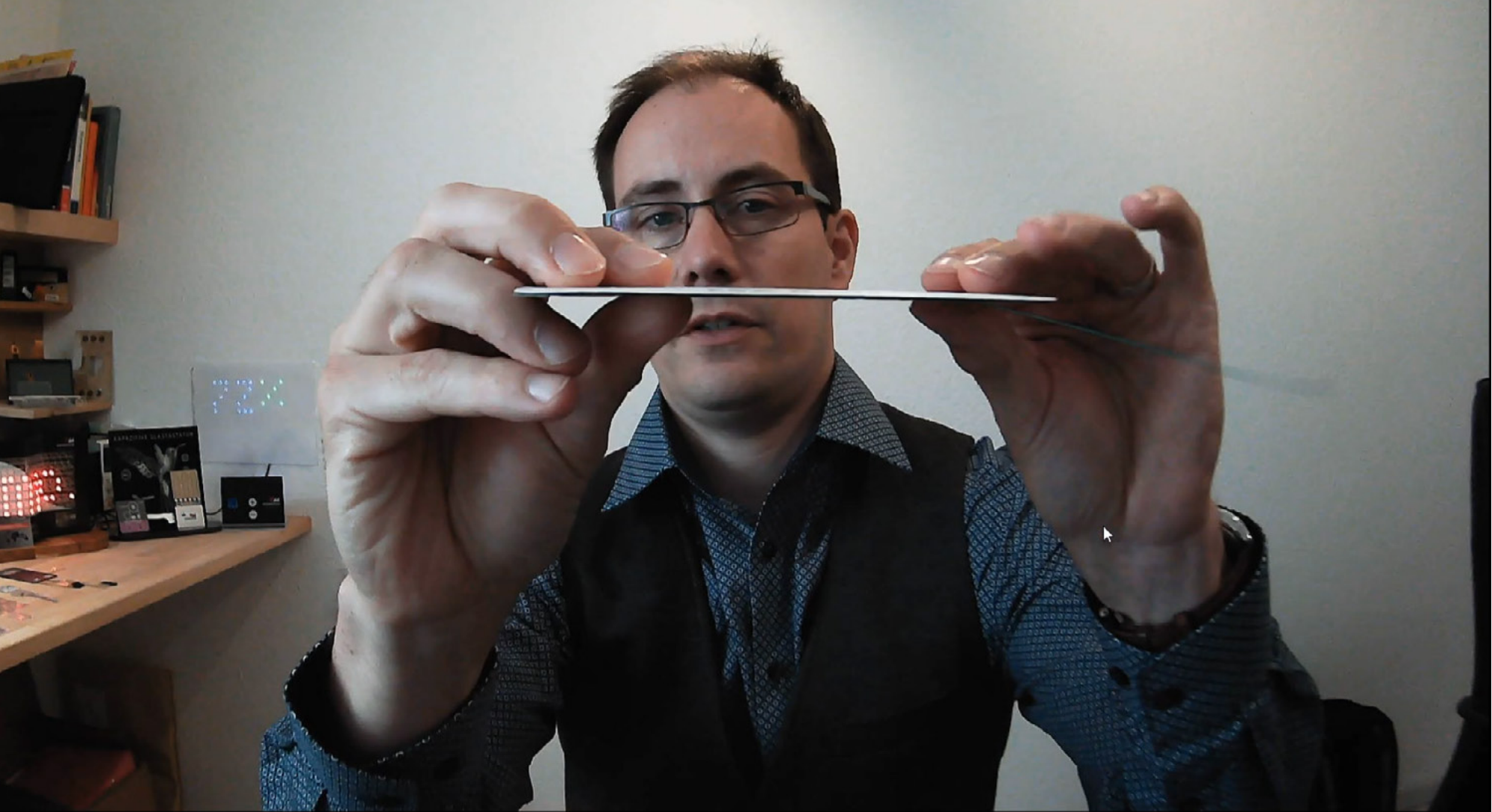





# Surface Finishing – Cover Film

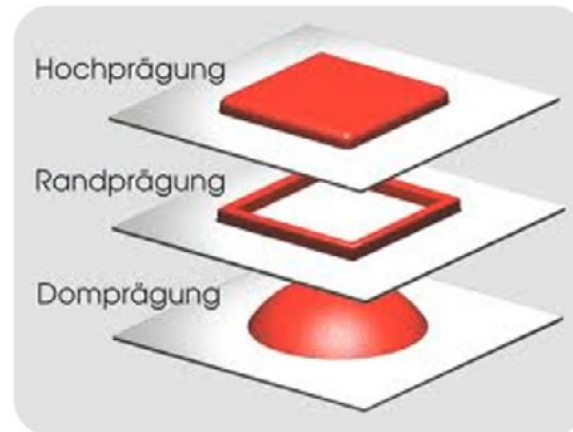
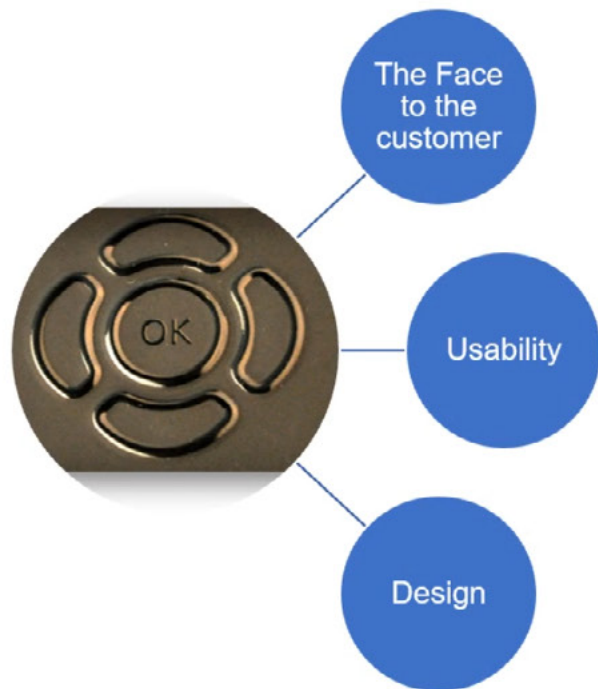

# Take Away Membrane Keyboards

- Early Design consideration of the HMI in an electronic unit enables a successful device
- Embossing and Colors are an important feature to the user perception
- Membrane Keyboards are robust
- Design is easily adjustable
- Versatile technology available



# Hybrid Systems (HMIs)



# More sophisticated HMI's

Integrating Components e.g.: LEDs, Resistors, Diodes, Microcontrollers → Hybrid Electronics

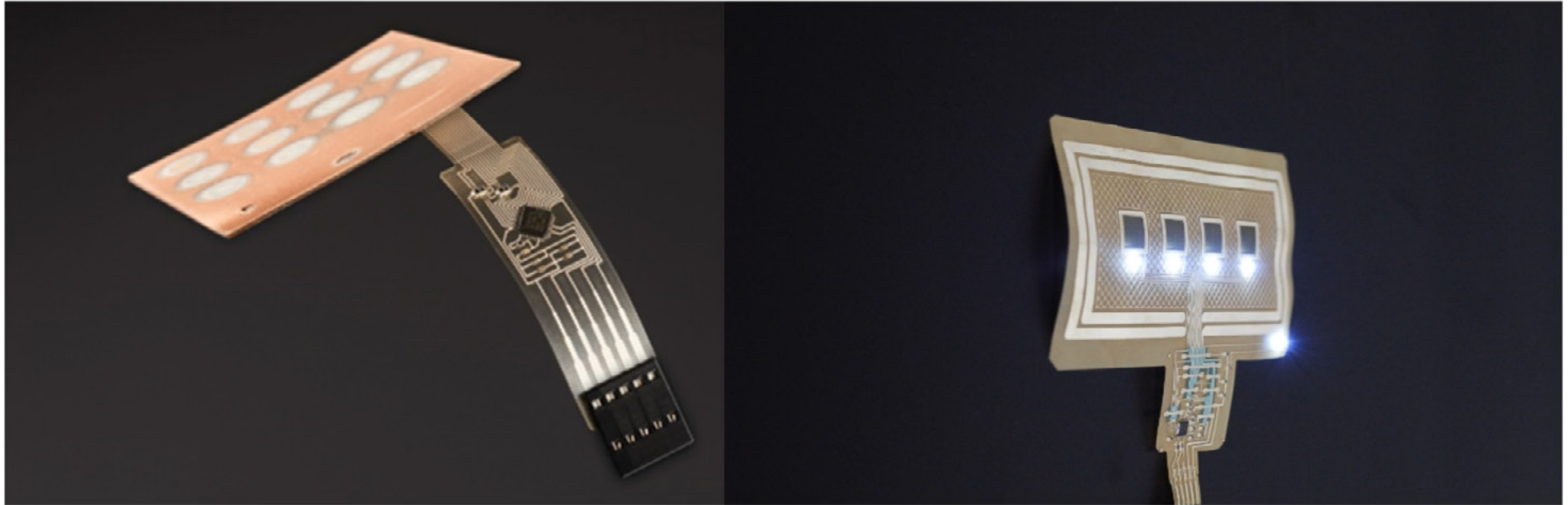

# Advanced Competencies

Electrical  
Design

Pick'n'  
Place

Soldering  
on PET

Embossing

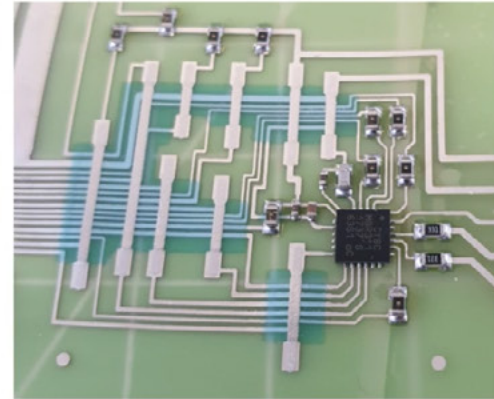
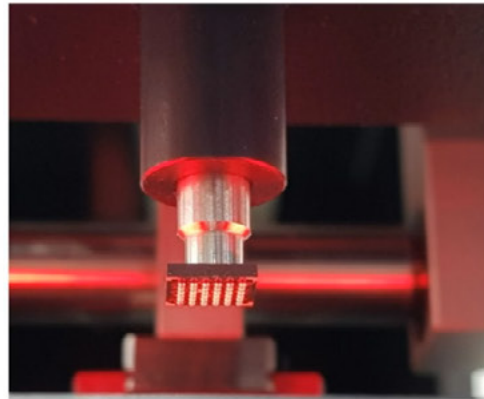
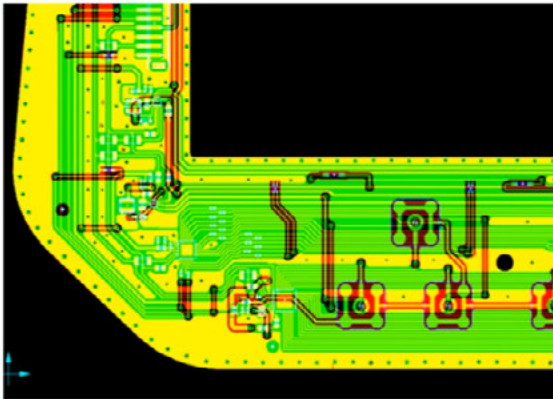

# SMD Soldering on PET

Lab Scale

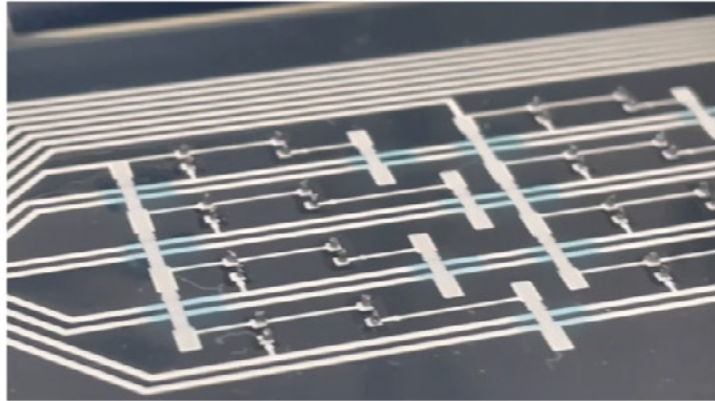

Dispensing solder paste



Lab Pick and Place

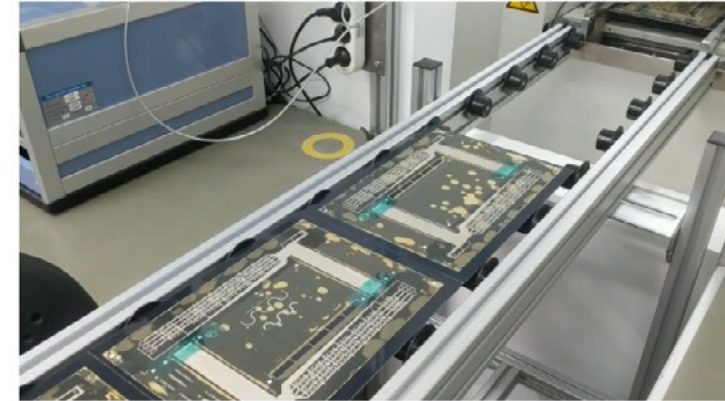

Reflow Ofen



# SMD Soldering on PET

Production Scale

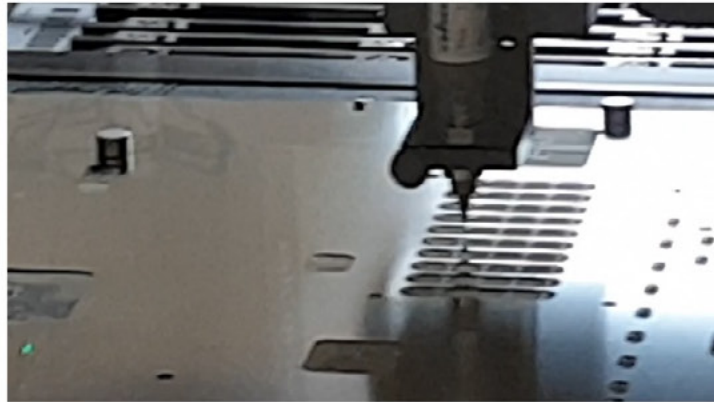

Dispensing solder paste

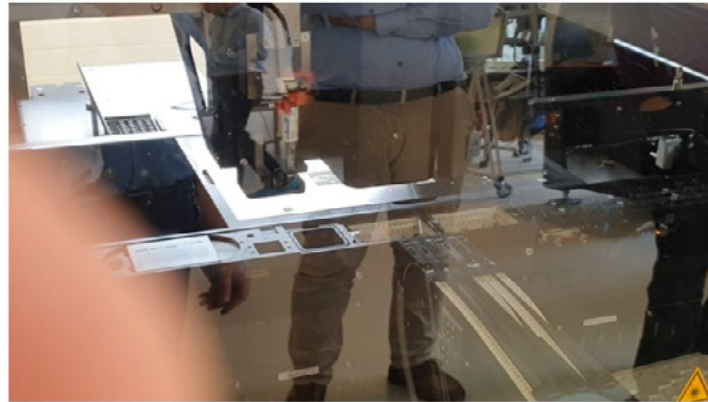

Pick and Place



Reflow Ofen finishing

Currently in setup



# Membrane Keyboard with segment display



# Example Hybrid Integration

- Saving material cost by integration
- Early design integration of Kundisch saves several parts by hybrid electronics
- Enclosure molded at Phoenix Mecano → Design to Cost process

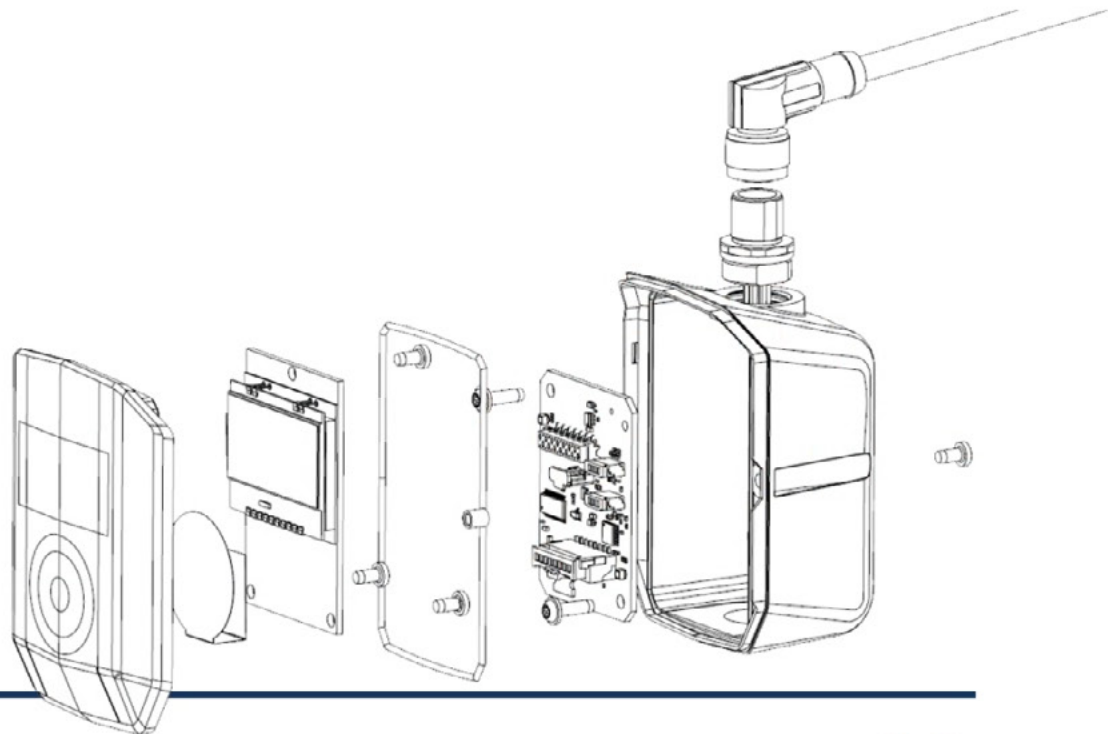

# Example Hybrid Integration

- Saving material cost by integration
- Early design integration of Kundisch saves several parts by hybrid electronics
- Enclosure molded at Phoenix Mecano → Design to Cost process

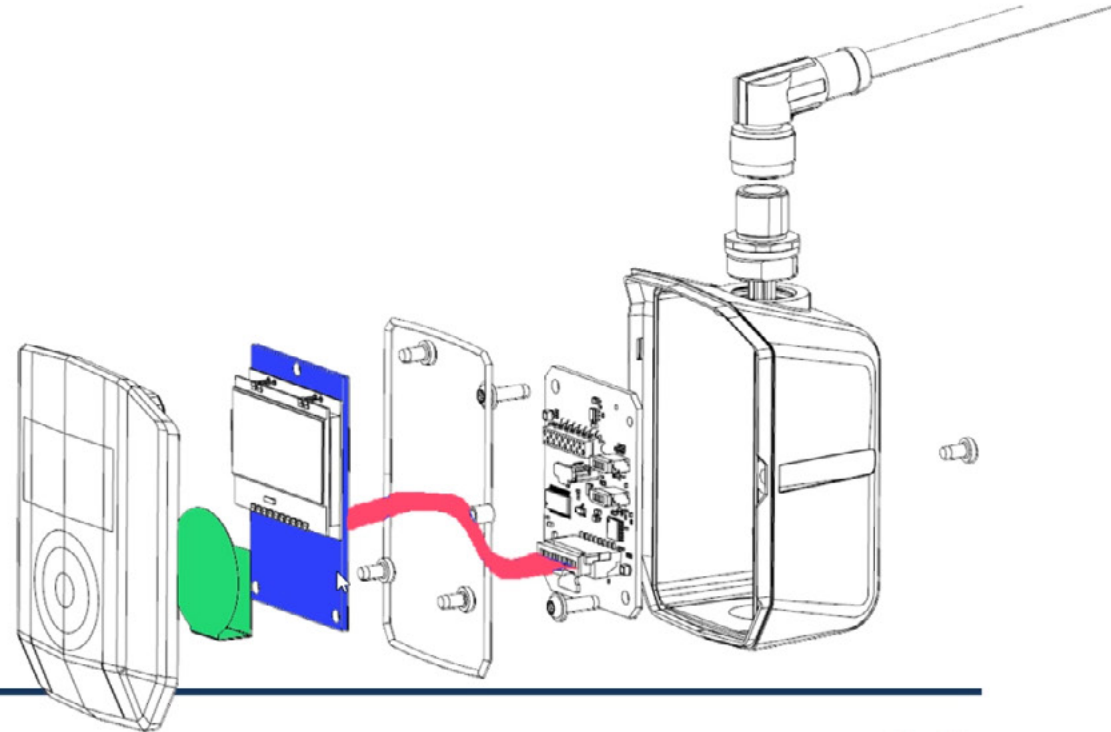
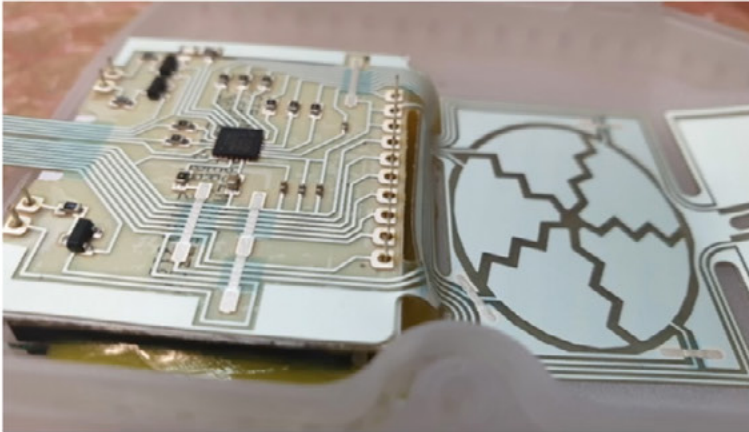



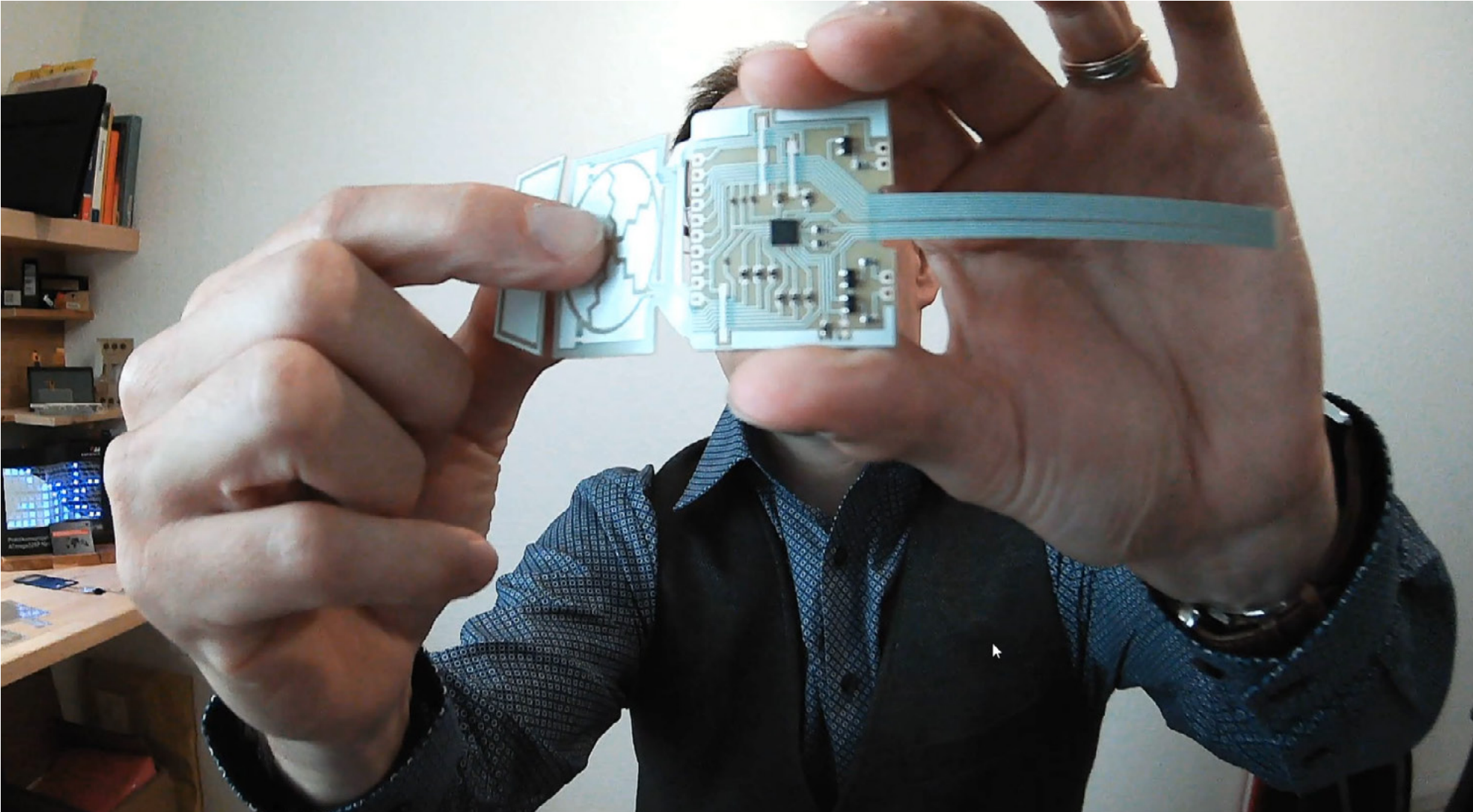



# Example Hybrid Integration

- Saving material cost by integration
- Early design integration of Kundisch saves several parts by hybrid electronics
- Enclosure molded at Phoenix Mecano → Design to Cost process

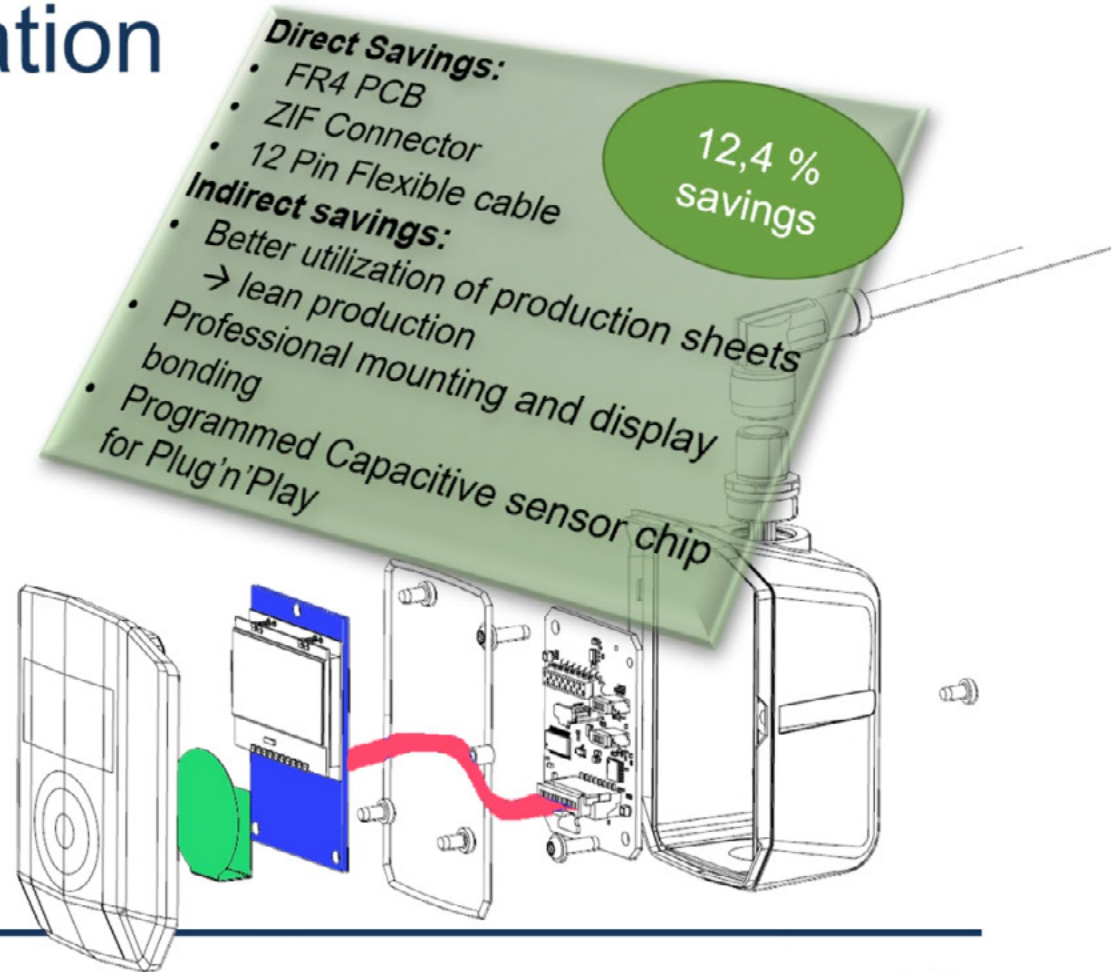
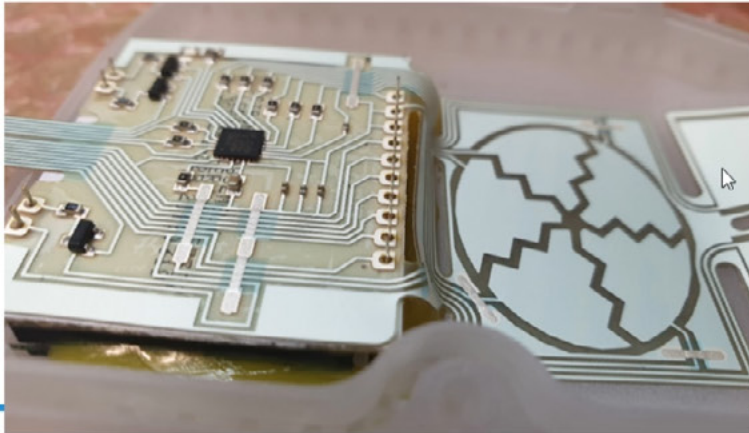

# Flexible LED Films

High Power LED as an 360° emergency signal light

Savings of 4 ridged single PCBs and 20 Minutes of manual mounting

**Direct Savings:**

- FR4 PCB
- Reduce Pick and Place Costs
- Manual mounting time reduced by 20 minutes

**Other Benefits:**

- True 360° illumination
- Less Weight

13 % savings

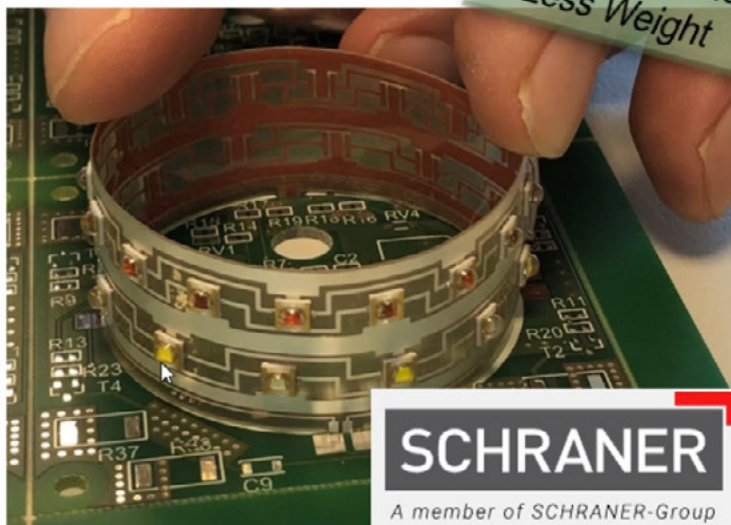

Mounting on PCB



High Power LEDs on PET







# NFC and Display integration



# Integrated NFC (RFID)

- Cost efficient integration of NFC Antennae in Keyboards and HMIs
- NFC (Near Field Communication 13.54MHz)
- Antenna is produced in one step with HMI
- Reader Hardware ( $\mu$ C) can seamlessly be integrated
- Design and Test of the Antenna can be done by Kundisch
- Specialized for low volume customized NFC Antennae production (<500.000 pcs)

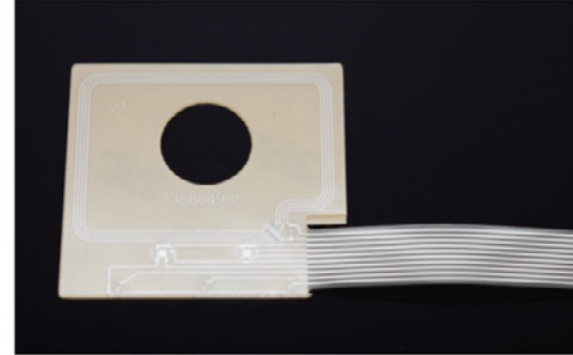

Passive NFC Antenna for customers reader

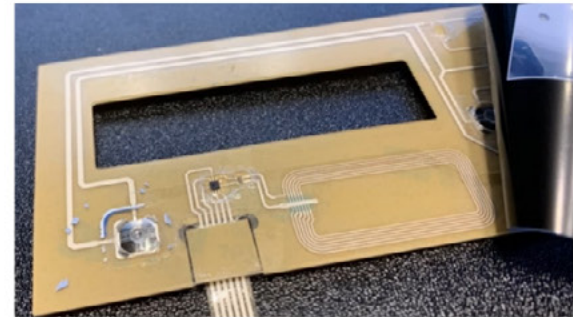

NFC To I<sup>2</sup>C Antenna with Chip

# Integrated NFC Reader

NFC Reader and E-Paper Display integrated in an appealing Cover Film of a plastic enclosure

Total thickness of the HMI Film 1.6mm

Optional keys can be integrated

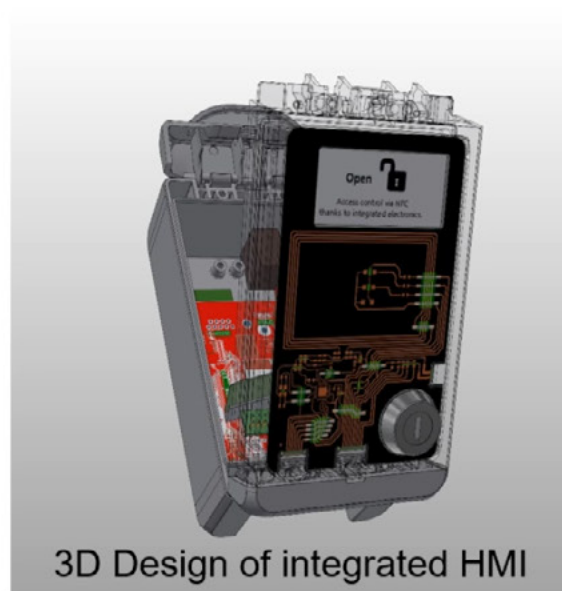

# Integrated NFC Reader

NFC Reader and E-Paper Display integrated in an appealing Cover Film of a plastic enclosure

Total thickness of the HMI Film 1.6mm

Optional keys can be integrated

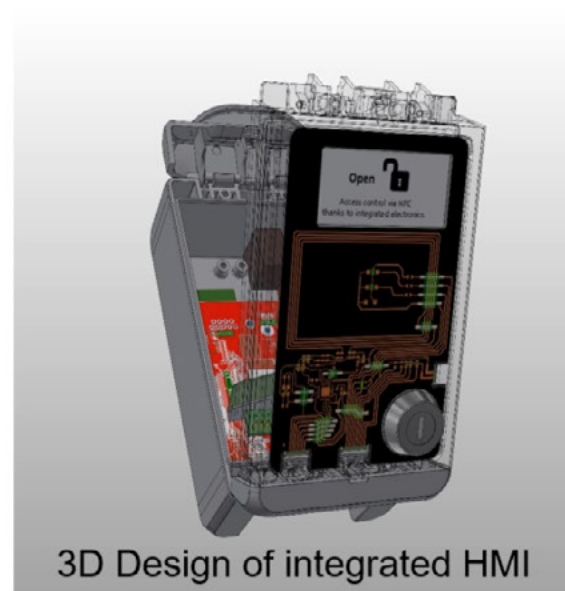









# Digital Label Key – E-Papers act as keys

- E-Paper Displays can be used as a membrane key
- The E-Paper itself can be imaged as needed and is integrated in a cover film
- It can be pushed on just like a regular key
  - Including tactile feedback

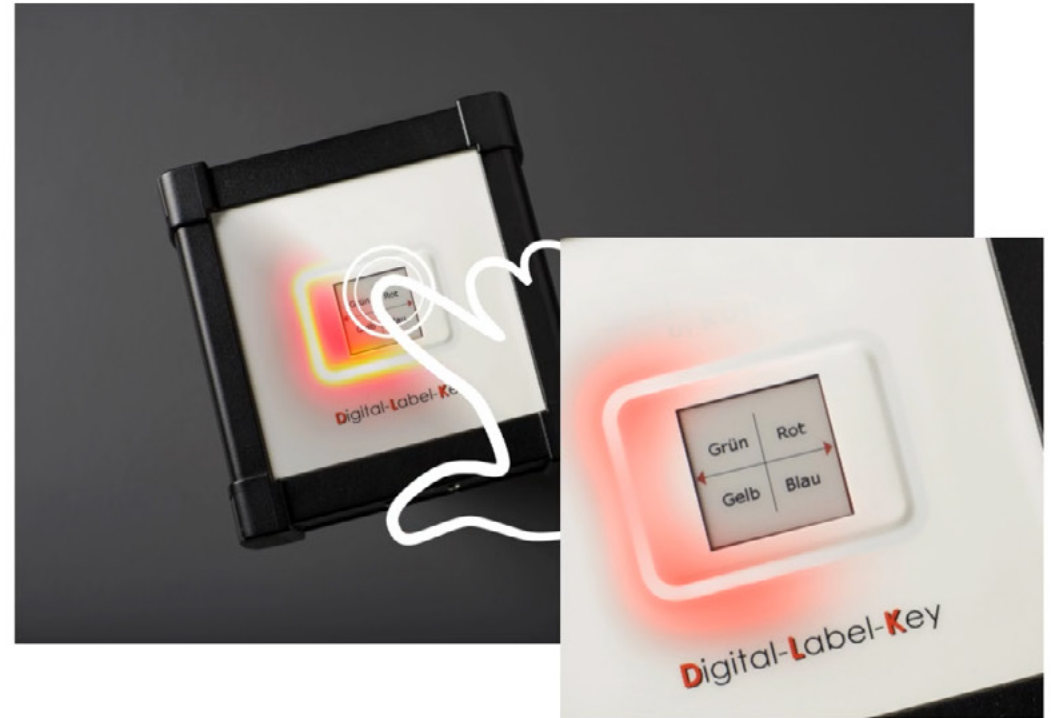



# Take Away Hybrid HMIs

- Hybrid HMIs enable even more features for end users
- The integration of more functions (Microcontrollers) enable new applications
- Displays (E-Paper) can be integrated and used as a key
- Serial connections (e.g. USB) reduce complexity when integrating an HMI
- Printed end traditional electronics are merging

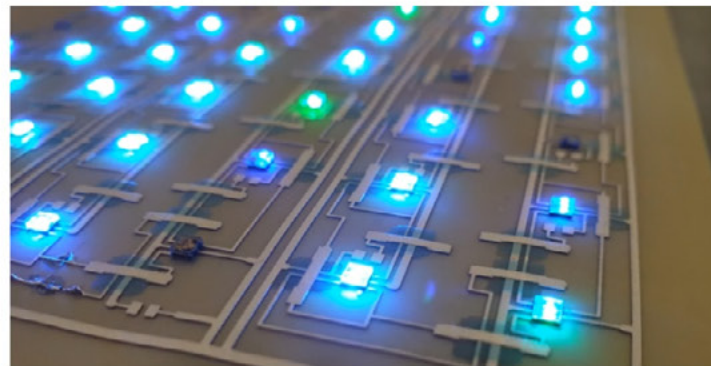





# Touch Systems

# Touch Systems

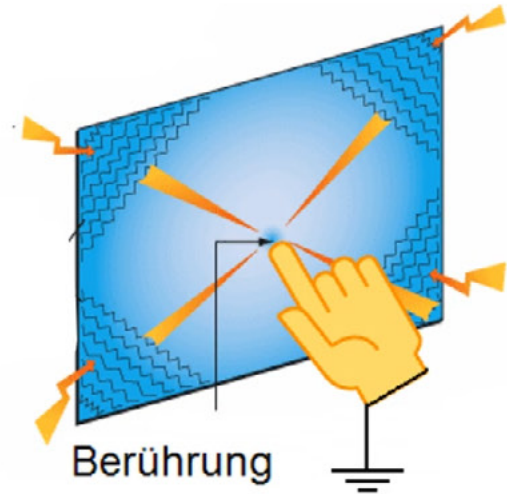

Capacitive

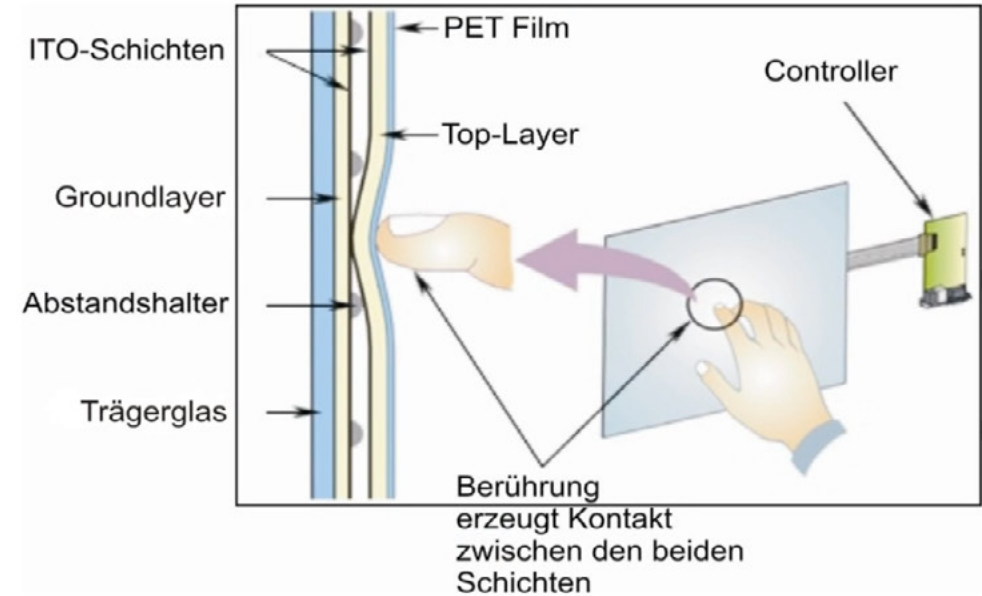

Resistive





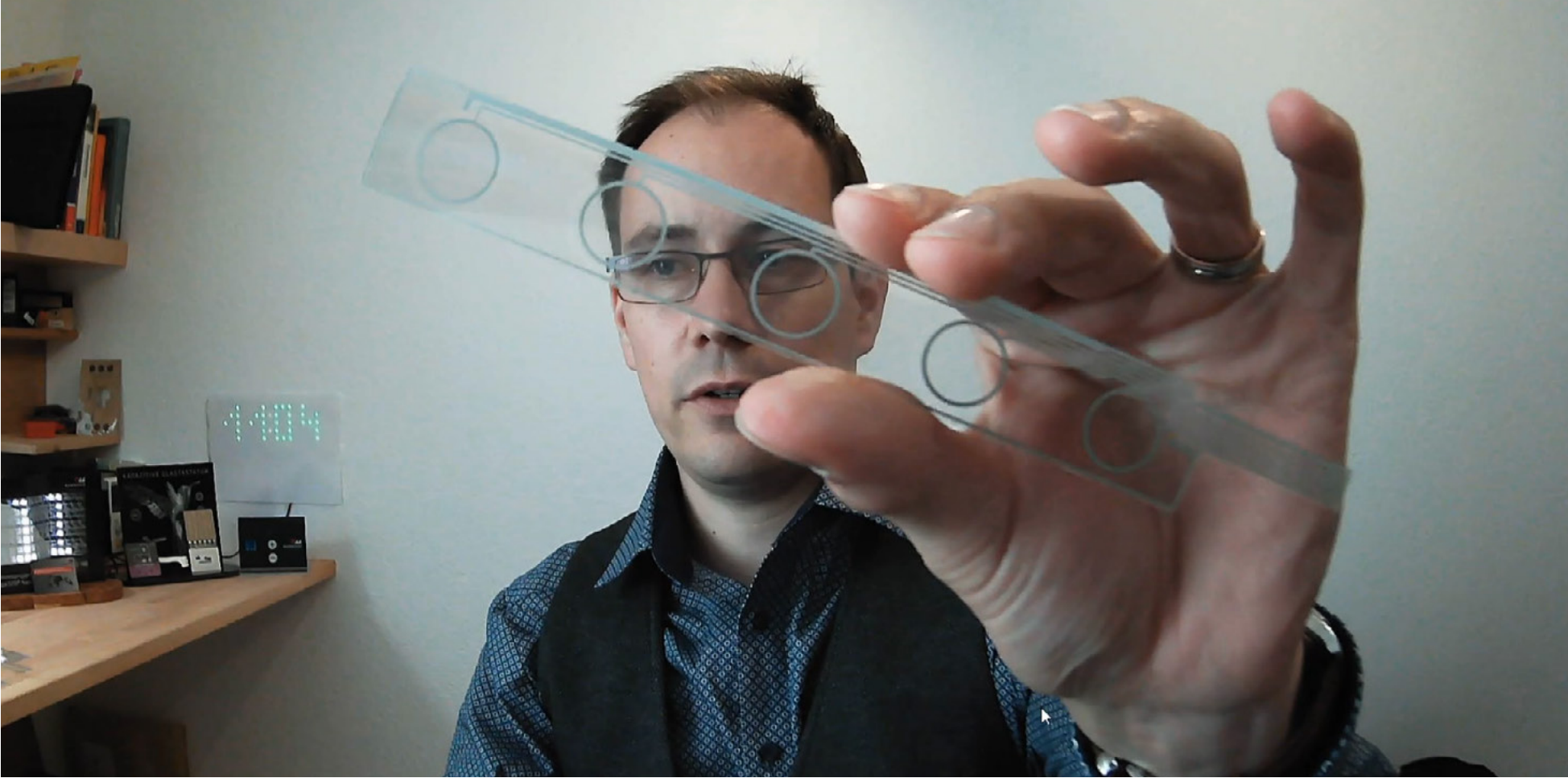





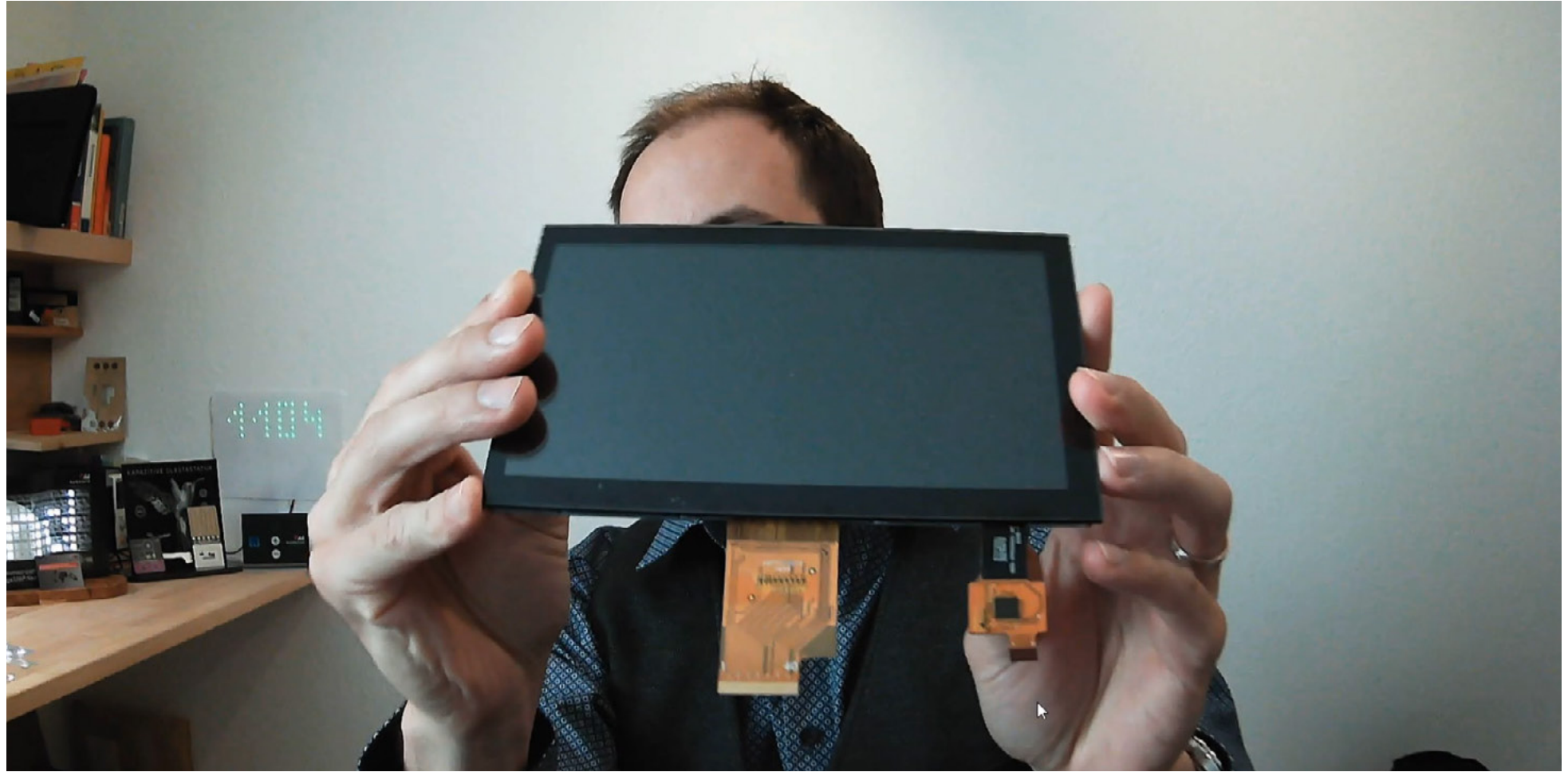

# Example Medical Care

Fully integrated Touch in a membrane keyboard

Not every touch is suitable for this technology

IP 67 can be achieved

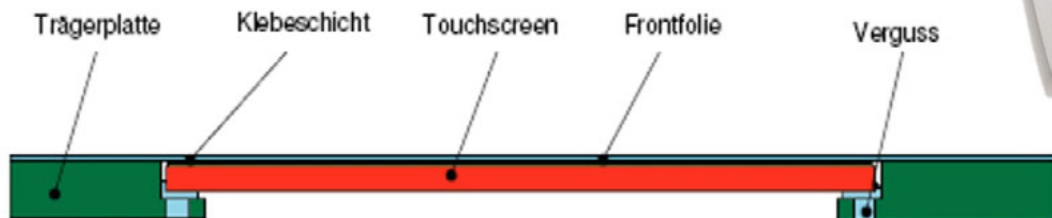



# Touch Integration Video



# Touch Integration Video



# Touch Integration Video

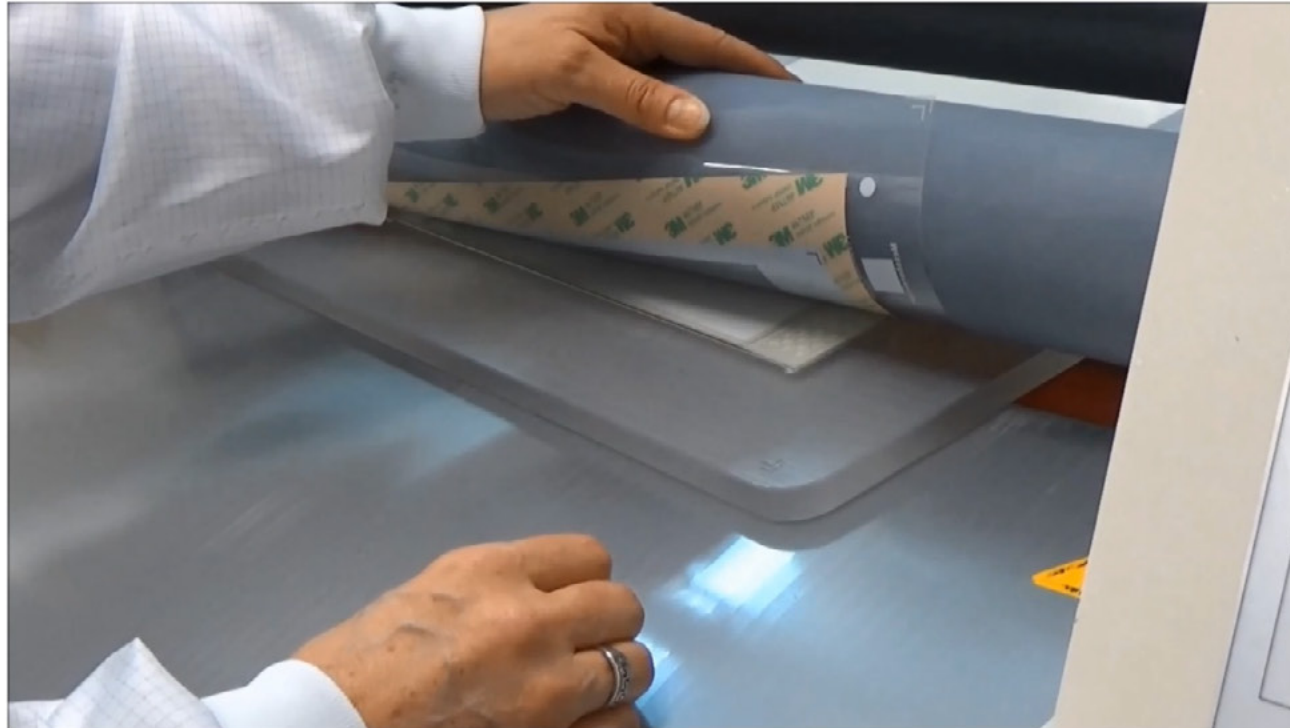

# Touch Integration Video

Montage  
des  
laminieren  
Touches



# Touch Integration Video

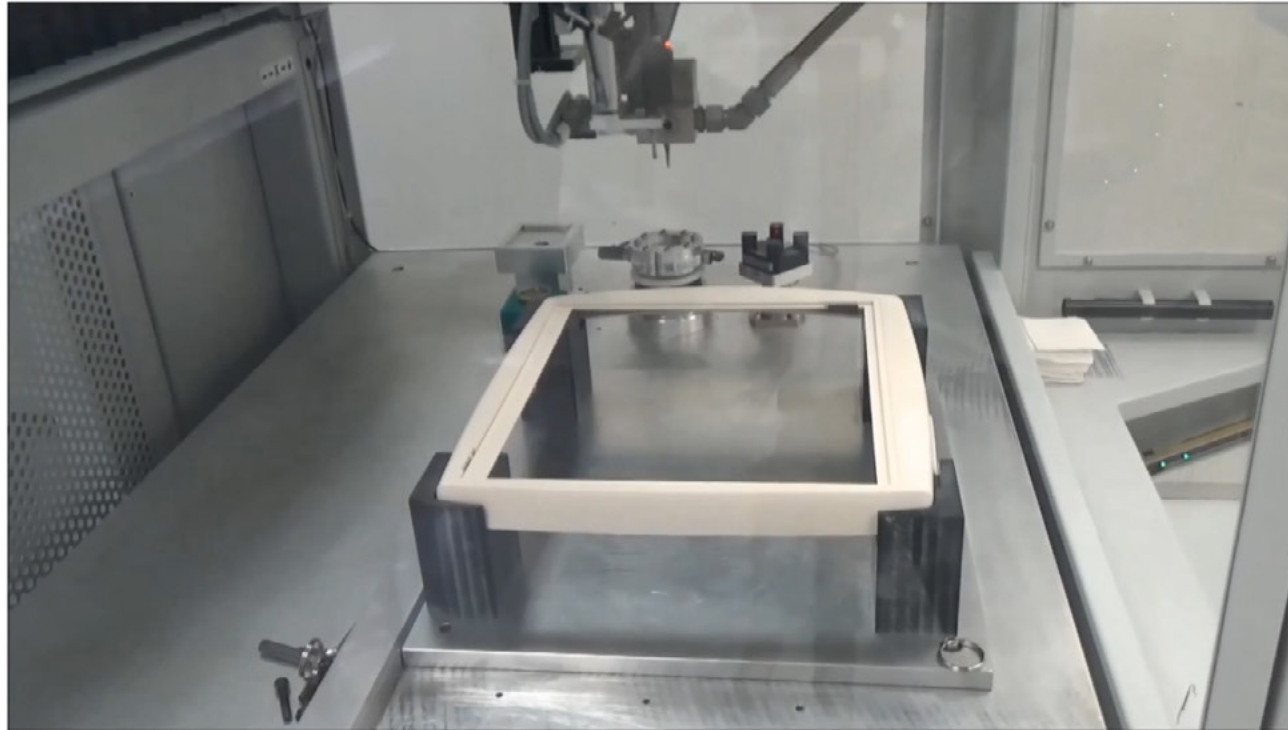

# Touch Integration Video

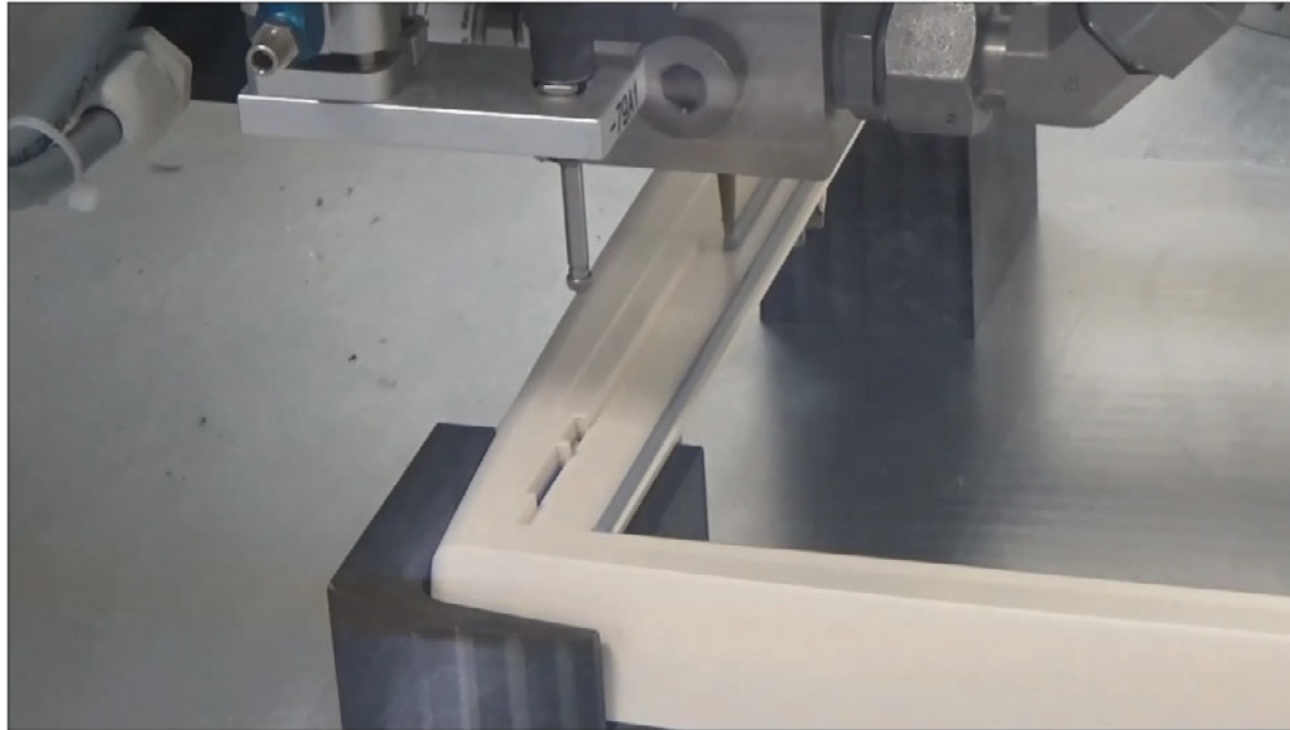

# Touch Integration Video

Verkleben des  
Frontrahmens

# Touch Integration Video





# Touch Integration Video



# Touch Integration Video



Endprüfung

# Touch Integration Video



# Touch Integration Video



Schlussreinigung



# Touch Integration Video

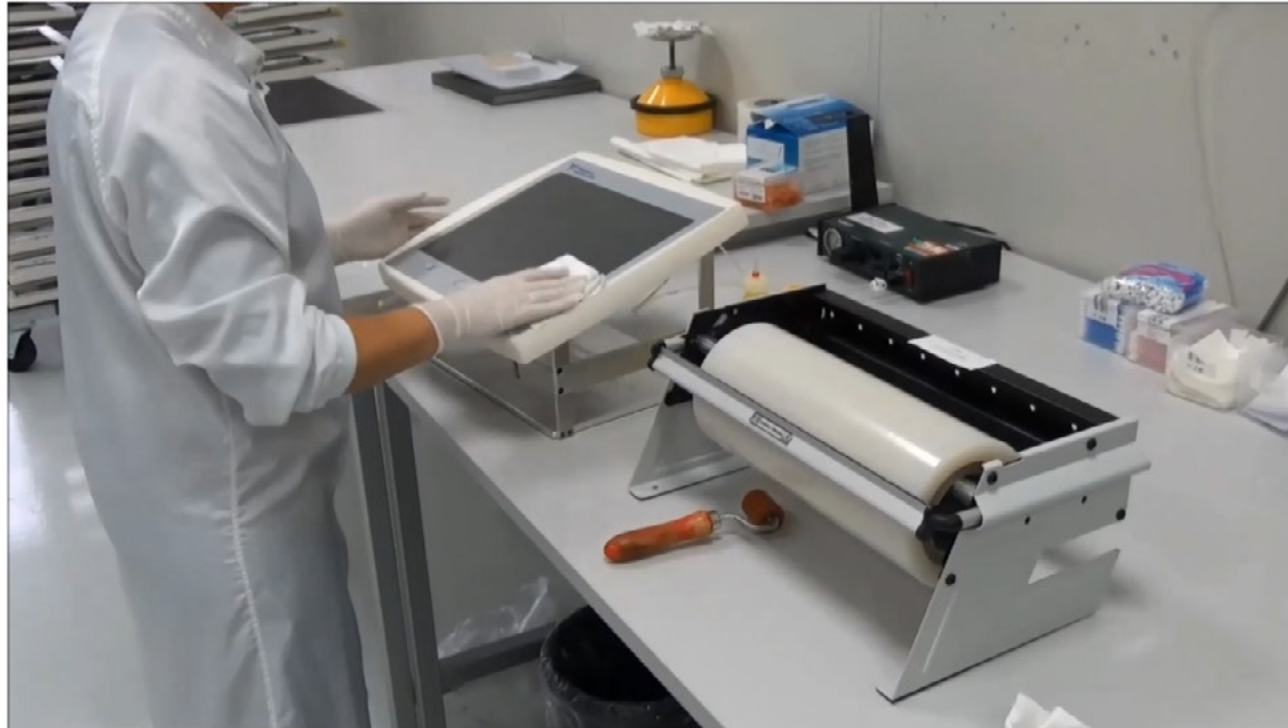

# Touch Integration Video

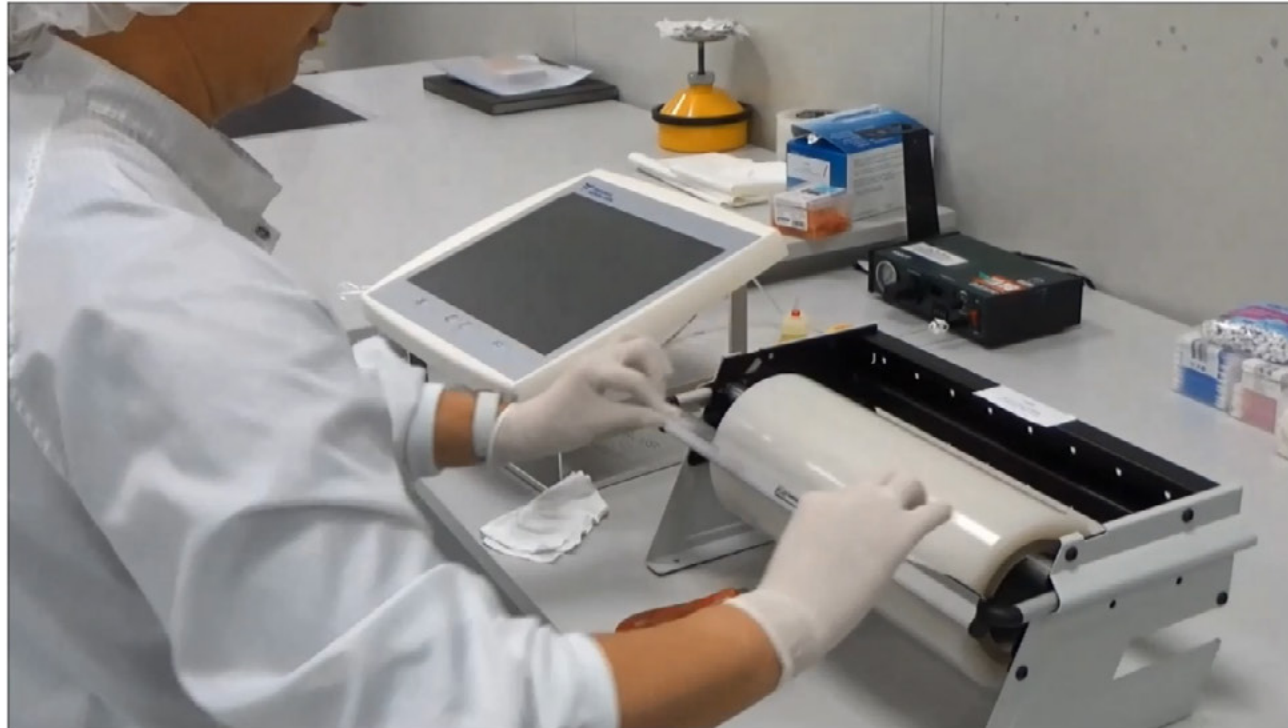

# Touch Integration Video

Vollflächiges  
Laminieren des  
Touches  
im Reinraum



# Quality inspection

- Each product is 100% tested before delivery.
- Often each product has a dedicated test routine
  - Touch linearity
  - Illumination homogeneity
  - HF Resonance Measurements





# Complex HMIs using Touch and Keys

- Combining the technologies of printing a membrane keyboard and integrating a touch yields the need for assembly of electronics units and testing of the like
- Complex systems are designed and built in one hand.

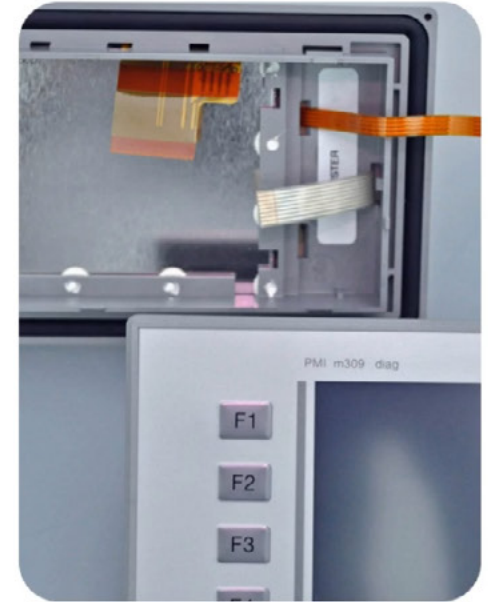
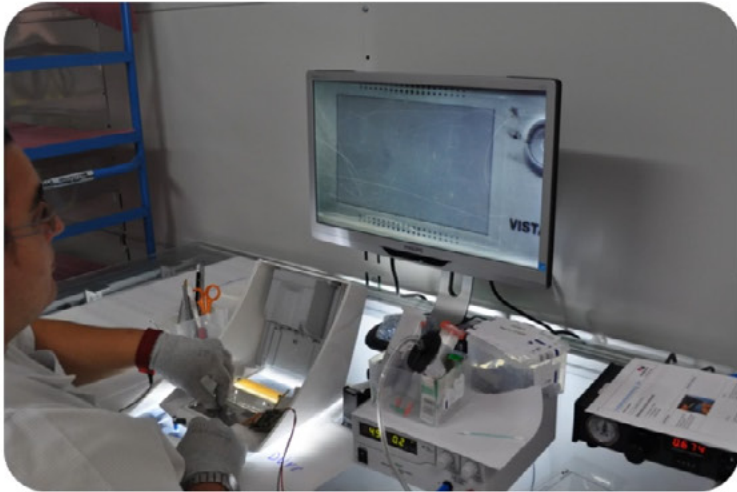

# Integration and Assembly of HMI Units

Baugruppen-  
montage



# Integration and Assembly of HMI Units



# Integration and Assembly of HMI Units

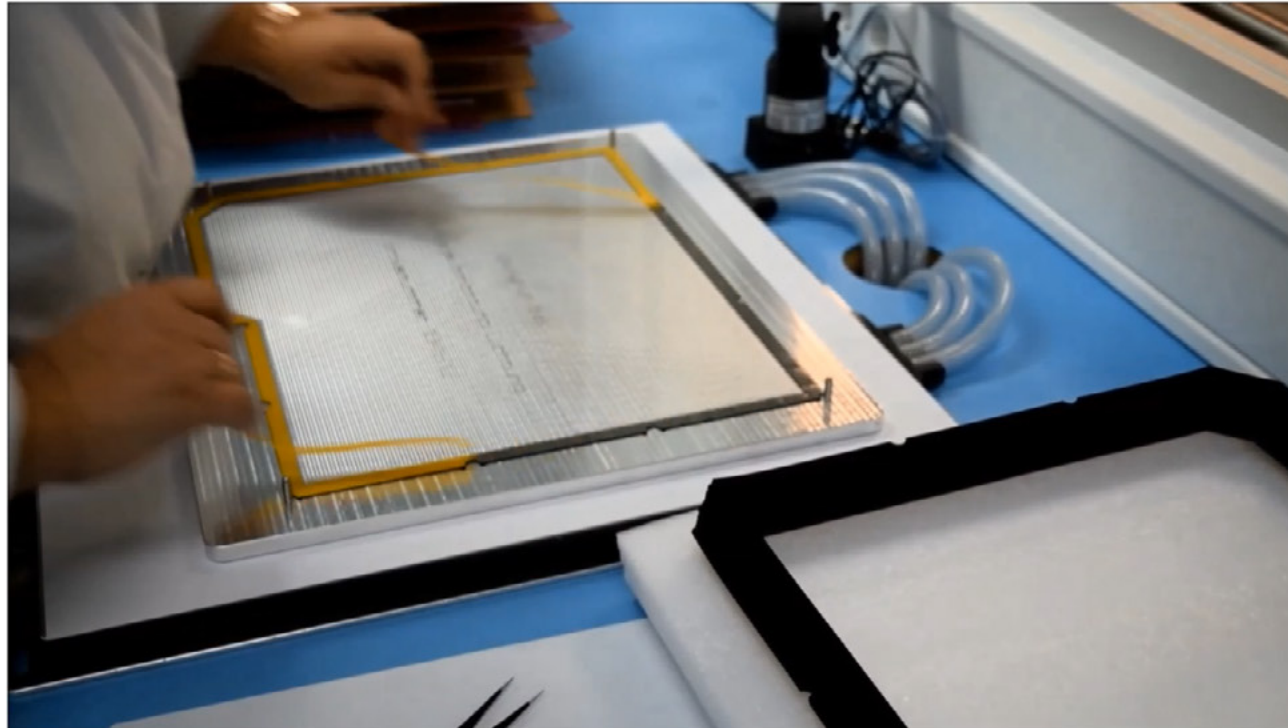



# Integration and Assembly of HMI Units



# Integration and Assembly of HMI Units



# Integration and Assembly of HMI Units



# Integration and Assembly of HMI Units



4



# Integration and Assembly of HMI Units



# Integration and Assembly of HMI Units



# Integration and Assembly of HMI Units



# Take Away Touch Systems

- Resistive and Capacitive Touches are State of the Art
- Touch Systems can be integrated with printed membrane keyboards
- Design of complex systems is crucial for a lasting product
- Complete assembly of HMI units saves resources and costs





# Summary

The HMI of a device is the machines “face to the customer”

Early integration of Kundisch in the Design yields a successful end-user experience

Versatile technologies and materials are available to design the best HMI for a specific device

Membrane Keyboards

Hybrid Electronics

Touch Systems

Integrated Display

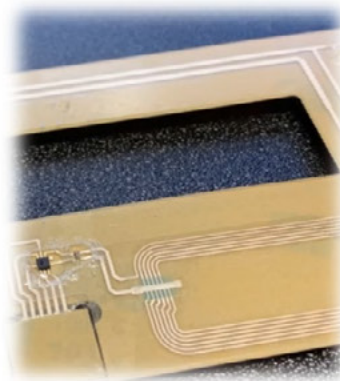

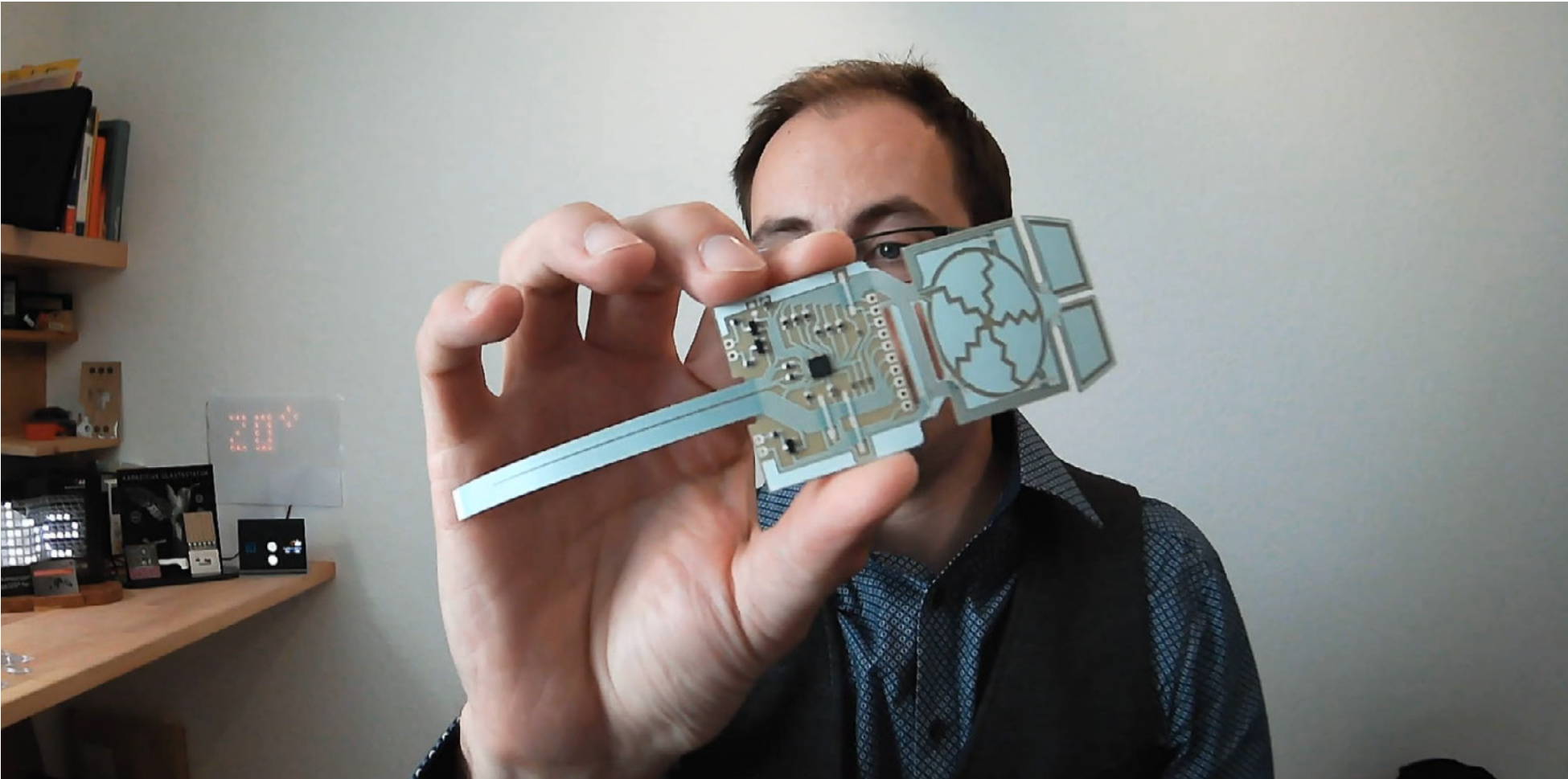

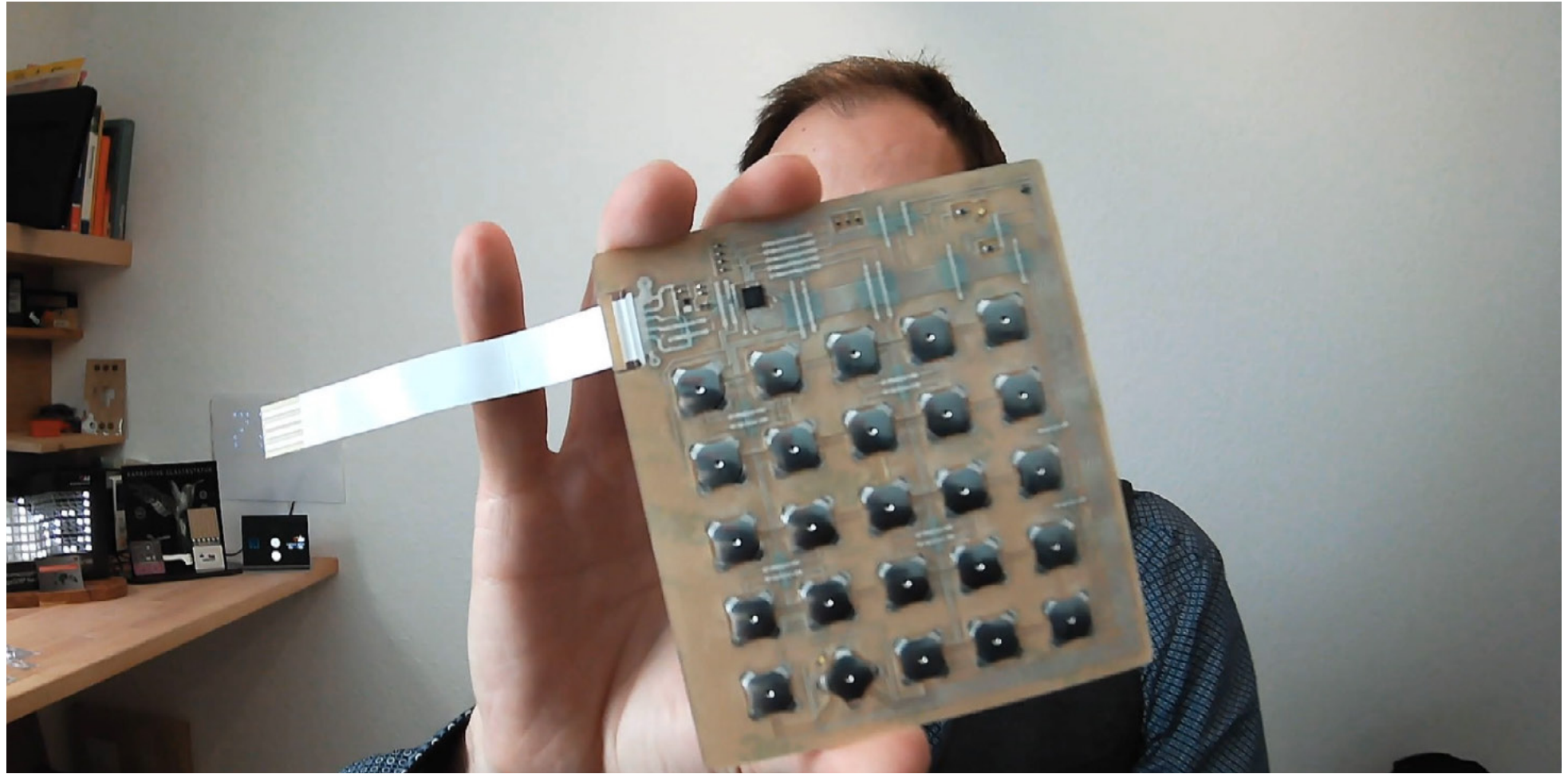









# Summary

The HMI of a device is the machines “face to the customer”

Early integration of Kundisch in the Design yields a successful end-user experience

Versatile technologies and materials are available to design the best HMI for a specific device

Membrane Keyboards

Hybrid Electronics

Touch Systems

Integrated Display

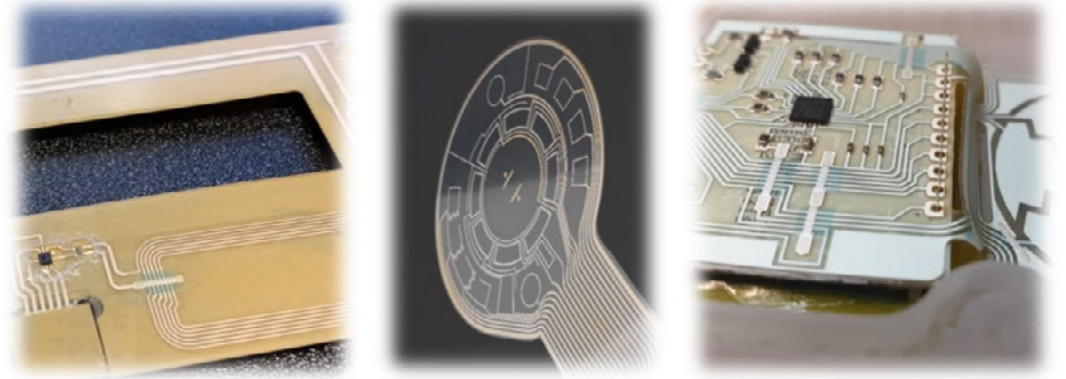

## Your partner for simple membrane keyboards and customized complex integrated HMI Systems



**Kundisch GmbH & Co. KG**  
Steinkirchring 56  
D-78056 VS-Schwenningen

Telefon +49 (0) 7720 97 61-0  
Internet: [www.kundisch.de](http://www.kundisch.de)  
Sebastian.Gepp@kundisch.de



**Touch the Future!**

Thank you



**PC Kundisch**  
Szent István krt. 24  
H-6000 Kecskemét

Telefon +49 (0) 7720 97 61-0  
Internet: [www.phoenix-mecano.hu](http://www.phoenix-mecano.hu)

